

BALOGH

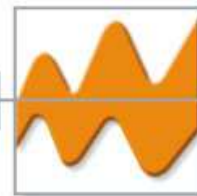

# MOS-200

## INSTALLATION MANUAL

Ref : MI-MOS-200-D-EN

Code : EN-13614-019-D

---

**BALOGH SA** ■ 189, rue d'Aubervilliers - C.P. 97 75886 PARIS Cedex 18 – France ■

■ Tél : 33 (0)1 44 65 65 00 ■ Fax : 33 (0)1 44 65 65 10 ■ web : <http://www.balogh-rfid.com> ■

S.A. à Directoire au Capital de 800 000 € - RCS B PARIS 582 061 073



---

**TABLE OF CONTENTS**

<b>1</b>	<b>PREAMBLE .....</b>	<b>4</b>
1.1	SUBJECT OF THIS MANUAL.....	4
1.2	UPDATES .....	4
1.3	DISCLAIMER .....	4
<b>2</b>	<b>COMPOSITION OF BRS SYSTEM.....</b>	<b>5</b>
<b>3</b>	<b>THE MOS-200 READER : MECHANIC INSTALLATION.....</b>	<b>6</b>
3.1	MECHANIC SPECIFICATIONS.....	6
3.2	INSTALLATION PLANS.....	6
3.2.1	<i>Perspective:</i> .....	6
3.2.2	<i>Bottom view:</i> .....	7
3.2.3	<i>Side view:</i> .....	7
3.2.4	<i>Front view:</i> .....	7
3.3	READER POSITION CONSTRAINTS.....	8
3.4	READER ENVIRONMENT CONSTRAINTS .....	9
<b>4</b>	<b>THE MOS-200 READER : ELECTRIC INSTALLATION .....</b>	<b>11</b>
4.1	CONNECTOR AND CABLING CONSTRAINTS .....	11
4.2	CONNECTOR'S PINOUT .....	12
4.3	PIN ASSIGNMENT CHART:.....	12
4.4	POWER SUPPLY .....	13
4.5	POSITIONING SIGNALS S1 AND S2 .....	13
4.6	IDENTIFICATION INTERFACE DATA TX .....	13
4.7	SERVICE INTERFACE CDE TEST RS422 .....	14
4.8	CONTROL SIGNALS PRES125KHZ; PRES6,78MHZ; BF .....	14

# 1 PREAMBLE

## 1.1 Subject of this manual

This manual explains how to install OMS-201 product.  
Performances and other characteristics are shown in other documents.

## 1.2 Updates

Version	Date	Writer	Description
B	27/11/2008	B.W.	Translation from FR-13614-019-B
C	20/10/2009	B.W.	Final casing dimensions and drawings
D	19/03/2010	B.W.	Dimensions of metallic installation environment

## 1.3 Disclaimer

BALOGH reserves the right to make changes to this manual without further notice.

BALOGH does not assume any liability arising out of errors, oversight, or misunderstanding of following informations.

## 2 Composition of BRS system

The tag localization subsystem is composed of:

- a reader embedded under the train (product code MOS-200)
- a beacon secured on the ground (product code OMS-201).

The reader is composed of a single unit equipped with a connector (bayonet lock 19 points).

The beacon is composed of a single unit. It communicates by radio-frequency with reader, and has no electrical connection on track side.

Upon passing over the beacon, the reader transfers various data (via the connector), among which a localisation top, when both casings' reference lines are vertically aligned.

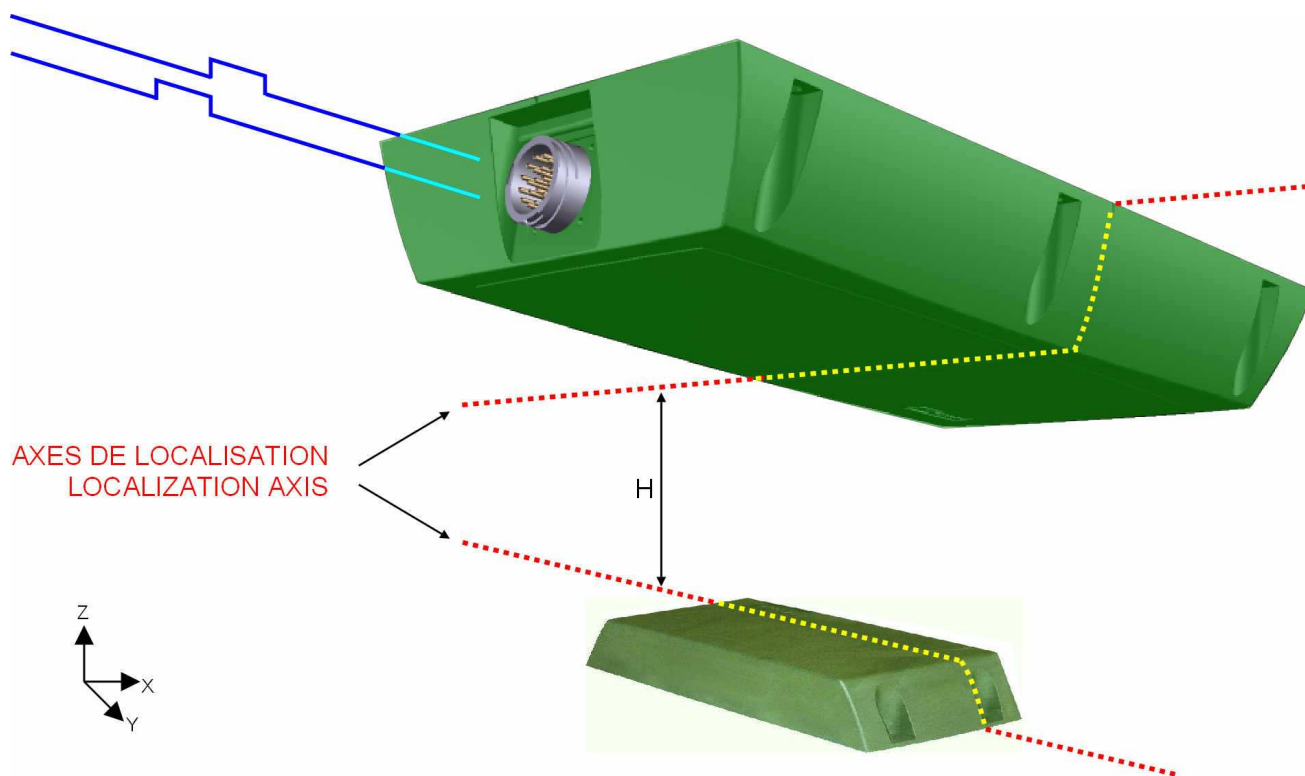

### Notice:

X shows longitudinal track axis (train movement direction)

Y shows transversal track axis

Z shows perpendicular track axis (vertical)

**BALOGH SA** ■ 189, rue d'Aubervilliers - C.P. 97 75886 PARIS Cedex 18 – France ■  
 ■ Tél : 33 (0)1 44 65 65 00 ■ Fax : 33 (0)1 44 65 65 10 ■ web : <http://www.balogh-rfid.com> ■

S.A. à Directoire au Capital de 800 000 € - RCS B PARIS 582 061 073

### 3 The MOS-200 reader : mechanic installation

#### 3.1 Mechanic specifications

Dimensions of bare casing:

- Length = 385mm
- Width = 256mm
- Height = 68mm

The following elements must be taken into account for the installation:

- The length is augmented by the connector and the entrance cable.
- Reader must be secured on metallic plate which width exceeds casing of 20mm minimum.

Total dimensions:

- Length including plug = about 470mm
- Overall length = about 600mm depending cable type
- Overall width including metallic plate = 296mm minimum

The securing of the reader will be carried out by means of 6 screws  $\varnothing$  6mm.  
Recommended tightening torque is 5Nm.

#### 3.2 Installation plans

##### 3.2.1 Perspective:

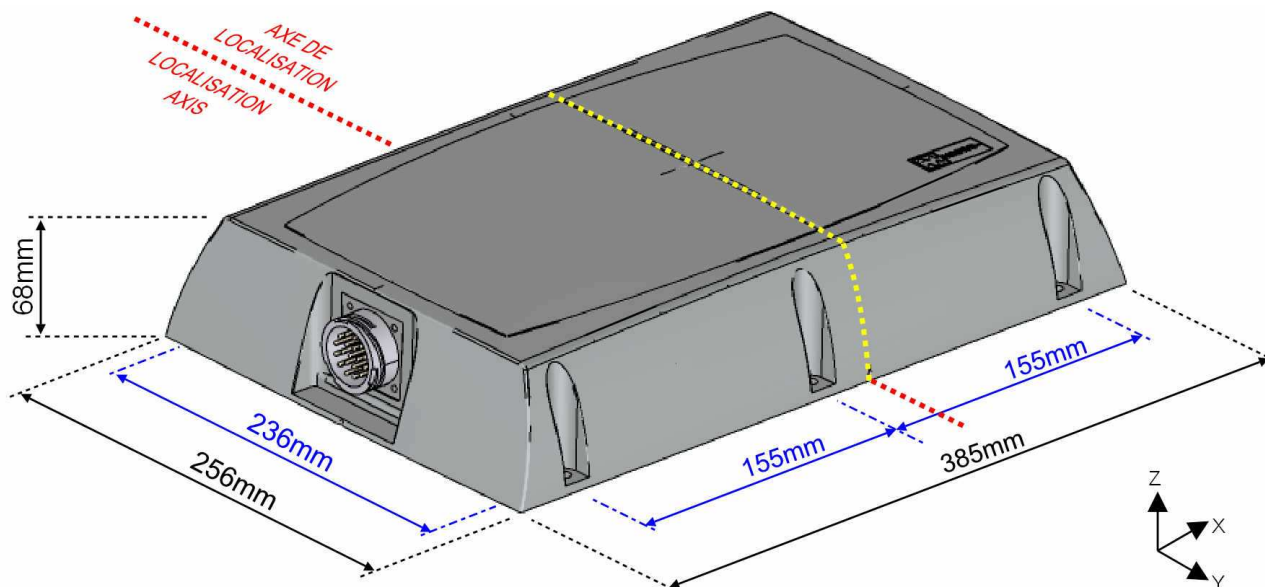

3.2.2 Bottom view:

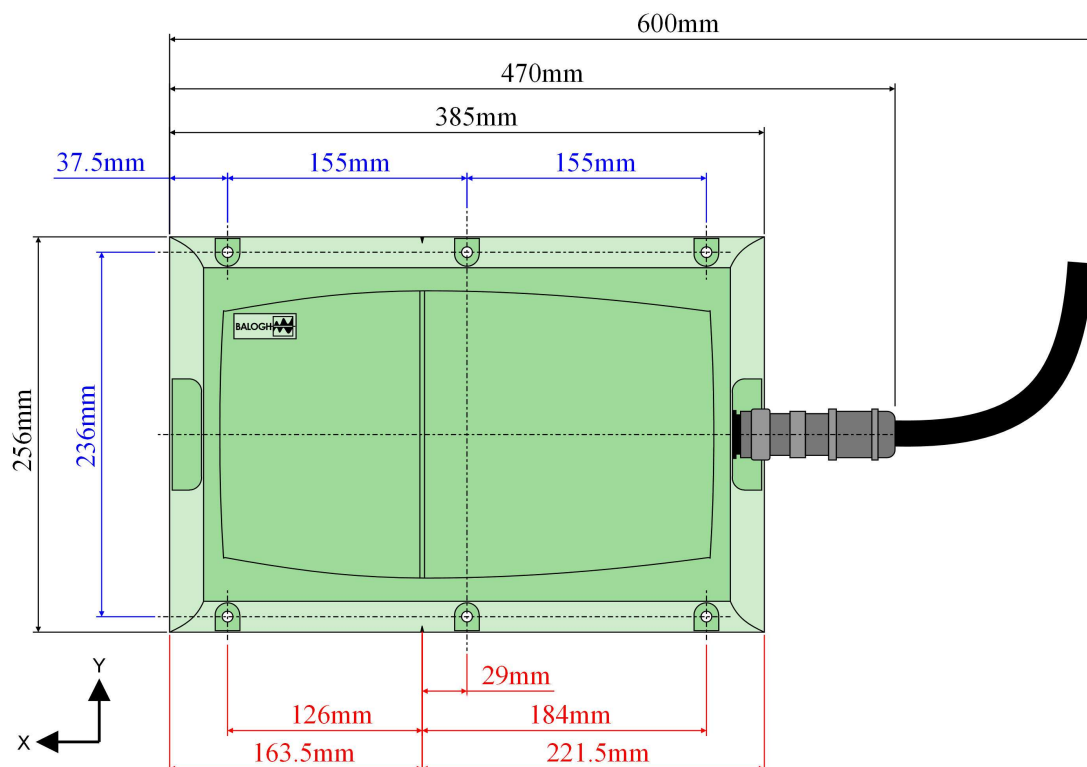

3.2.3 Side view:

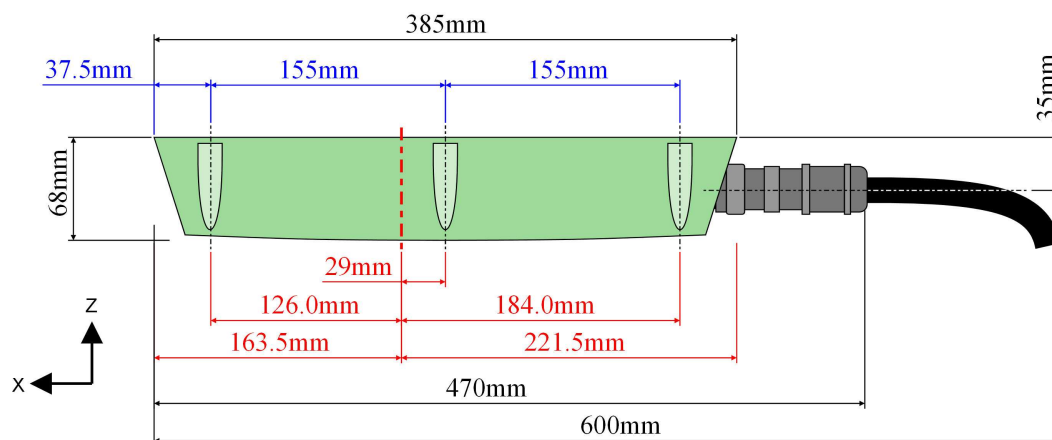

3.2.4 Front view:

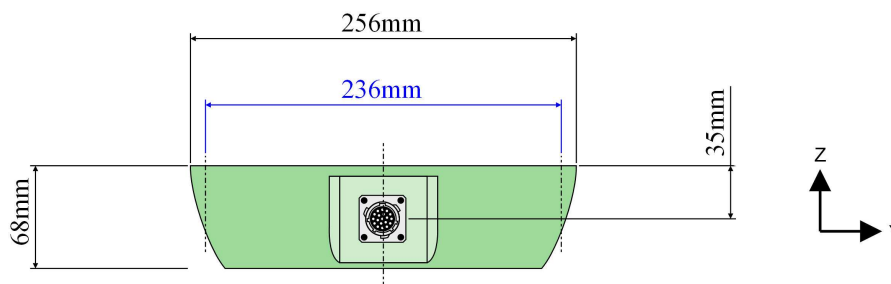

### 3.3 Reader position constraints

- The reader should be installed in the longitudinal direction (length of casing = length of train).
- The reference axis for localisation should be offset by 29 mm from the casing axis (opposite direction from connector) and is marked on casing.
- Based on such offsetting, the reader may be invariably installed with connector facing front or rear of train.
- Distance H between under side of each reader and top side of each beacon of one installation must be between 60mm and 200mm.
- Tolerances of position to be observed for installing :  
Lateral and angular tolerances of position must apply between each reader and each beacon of one installation. Indications below concerning reader versus train installation are only suggestions

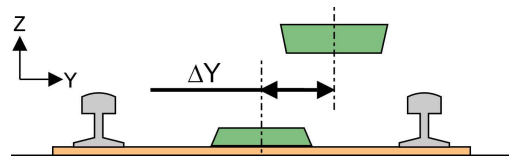
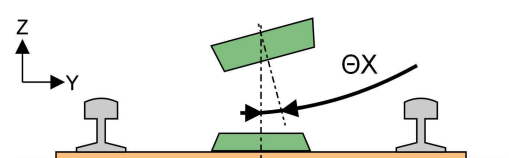
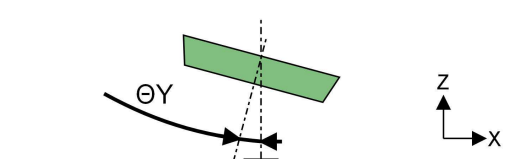
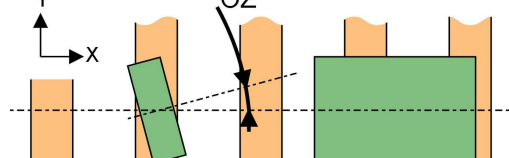
			Readers versus aux beacons	Reader versus train	Beacon versus track
$\Delta Y$	Lateral decentring		<b>+/- 10mm</b>	+/- 2mm	+/- 8mm
$\Theta X$	Lateral inclination to the horizontal plane		<b>+/- 10°</b>	+/- 2°	+/- 8°
$\Theta Y$	Longitudinal inclination to the horizontal plane		<b>+/- 15°</b>	+/- 3°	+/- 12°
$\Theta Z$	Rotation around the vertical axis		<b>+/- 5°</b>	+/- 1°	+/- 4°

### 3.4 Reader environment constraints

- The distance between 2 readers on the same train must be a minimum of 5 meters (500 cm).
- The reader should be secured on a metallic support 385mm x 296mm minimum (metallic plane exceed 2cm on large sides of the reader) :

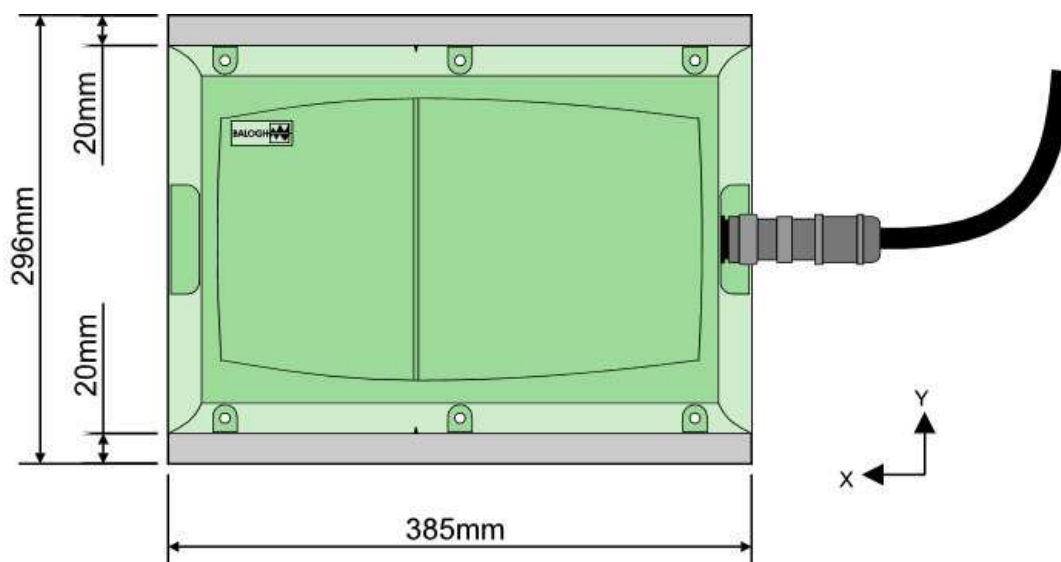

- If metallic parts are situated near the reader, distances to observe are indicated in the figures below (coloured = no metal area):

Transversal direction:

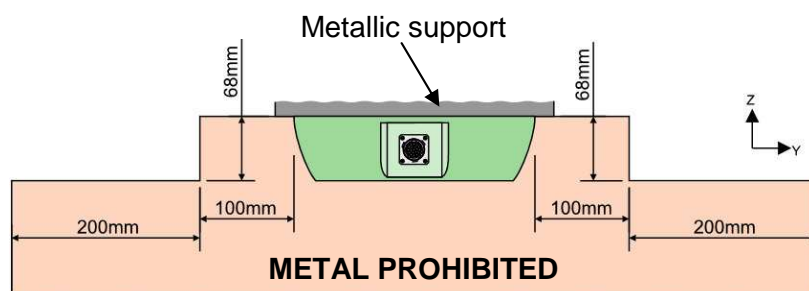

Longitudinal direction:

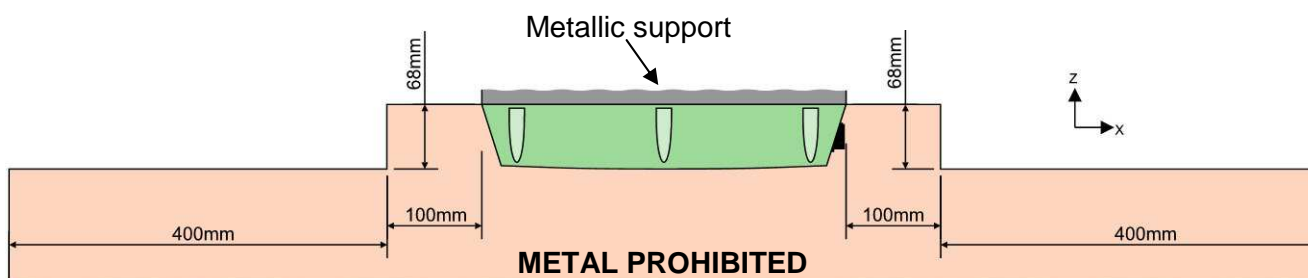

**BALOGH SA** ■ 189, rue d'Aubervilliers - C.P. 97 75886 PARIS Cedex 18 – France ■  
 ■ Tél : 33 (0)1 44 65 65 00 ■ Fax : 33 (0)1 44 65 65 10 ■ web : <http://www.balogh-rfid.com> ■  
 S.A. à Directoire au Capital de 800 000 € - RCS B PARIS 582 061 073



## **4 The MOS-200 reader : electric installation**

### **4.1 Connector and cabling constraints**

The brand of the connector used is SOURIAU, series UTO, size 16, 19 pins.

The male connector (MOS-200 reader side) socket's reference is:

shell: UTO01619PH

pins: RM20M12E8K

The female connector (cable side) plug's reference is:

Shell: UTO61619SH

Sockets: RC16M23K (for example)

Backshell and cable gland: UTOS16JCSL (for example)

The female plug's sockets may be selected according to the gauge of the conductors of the cable used. The reference indicated above is adapted to wires whose section is comprised between  $0.52\text{mm}^2$  and  $1.50\text{mm}^2$  (AWG16 to AWG20). See SOURIAU documentation for other applicable references.

The female plug's cable clamp should be selected according to the external diameter of the cable used. The reference indicated above is adapted to a cable whose diameter is comprised between 13.5mm and 18mm. See SOURIAU documentation for other applicable references.

The cable should be shielded. Shield connection should be correctly carried out at plug's cap: gland must assure 360° connectivity on cable shielding. See SOURIAU documentation for the suitable procedure.

## 4.2 Connector's pinout

External front view of the reader connector socket (and rear view of the cable plug):

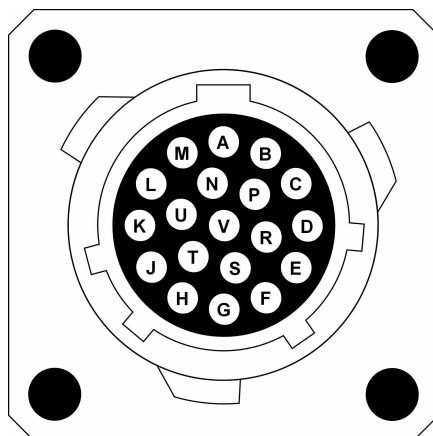

## 4.3 Pin assignment chart:

Pin	Assignment
A	110VDC
B	0VDC
C	CdeTest_RS422_RX-
D	Data_TX_422-
E	Data_TX_422+
F	0V
G	S2
H	0V
J	S1
K	0V
L	Pres125KHz
M	Pres6,78MHz
N	BF (Good Operation)
P	CdeTest_RS422_TX+
R	CdeTest_RS422_RX+
S	0V
T	0V
U	0V
V	CdeTest_RS422_TX-

#### 4.4 Power supply

- Voltage to be supplied : 110V CC
- Current used : 0.5A max.
  
- pin A : 110Vdc
- pin B : 0Vdc

#### 4.5 Positioning signals S1 and S2

- Type of link: digital output
- Level "0": high impedance
- Level "1": 19V / 40mA
  
- Maximum length of cable: 200 m
- Maximum total capacity of cable: 20nF
  
- pin J : S1
- pin G : S2
- pin F : 0 V reference
- pin H : 0 V reference

#### 4.6 Identification interface Data Tx

- Type of link: RS422 (transmission only)
- Rate: 62.5kbits/s
  
- Maximum length of cable: 200 m
  
- pin D : Data Tx 422-
- pin E : Data Tx 422+
- pin S : 0 V reference

#### 4.7 Service interface Cde Test RS422

- Type of link : RS422 (bidirectional)
- Rate : 9600bits/s
  
- Maximum length of cable : 200 m
  
- pin P : Cde Test RS422 Tx+
- pin V : Cde Test RS422 Tx-
- pin R : Cde Test RS422 Rx+
- pin C : Cde Test RS422 Rx-
- pin T : 0 V reference

#### 4.8 Control signals Pres125KHz; Pres6,78MHz; BF

- Type of link: Digital Output
- Level "0" : high impedance (except Pres125KHz: 1V)
- Level "1" : 19V / 40mA (except Pres125KHz: 15V / 40mA)
  
- Maximum length of cable: 200 m
- Maximum total capacity of cable: 20nF
  
- pin L : PRES 125KHz
- pin M : PRES 6,78MHz
- pin N : BF
- pin K : 0 V reference
- pin U : 0 V reference