

BICN

ControlNet Interface

BALOGH

7699 Kensington Court
Brighton, MI 48116-8561
(248) 486-7343



Notes are used to call attention to information that is significant to the understanding and operation of equipment.

This BALOGH manual is based on information available at the time of its publication. We have attempted to provide accurate and up-to-date information. This document does not purport to cover all details or variations in hardware or software; nor does it provide for every possible combination of products. Some features described herein may not be available on all like products. BALOGH assumes no obligation to notify holders of this document of any subsequent changes. For the latest up-to-date information and specifications on BALOGH products, contact the BALOGH web site at: <http://www.balogh-group.com>

BALOGH makes no representation or warranty, expressed, implied or statutory with respect to, and assumes no responsibility for the accuracy, completeness, or usefulness of the information contained in this manual. No warranties of merchantability or fitness for purpose shall apply.

Revision: November 7, 2002 © Copyright BALOGH 2000

Introduction.....	Page 1
Network Topology.....	1
Related Hardware and Software.....	2
Mechanical Specifications.....	2
BICN Power Requirements.....	3
Network LEDS.....	3
Channel Health Indications.....	3
DIP Switches.....	5
Network Address.....	5
Data Rate.....	6
Connections.....	7
Connection Pinouts and Mating Types.....	7
Power Connections.....	8
BICN Set-Up on a ControlNet[®] Network.....	9
I/O Size And Network Parameters.....	10
Register the EDS File.....	11
Adding a BICN to a CNB module ControlLogix Platform.....	17
Schedule the Network.....	21
Adding a BICN to a PLC-5C platform.....	26
Communications Description.....	32
Scheduled Data.....	34
Scheduled Data Input Image.....	35
Module Status Word.....	36
Dynamic Status Word.....	37
Specific Fault Codes.....	37
Operation Status Result Word.....	38
Fixed Code Read Results Field.....	39
Scheduled Data Output Image.....	40
Command and Memory Summary.....	41
TAG Block Write Command.....	42

Table of Contents

TAG Block Write Command.....	43
Discontinuous TAG Read Command.....	44
TAG Fill Command.....	46
Reset Request Command.....	47
Discontinuous TAG Write Command.....	48
Block Write Program Example (Control Logix).....	50
Block Read Program Example (Control Logix).....	54
Block Write Program Example (PLC-5).....	58
Block Read Program Example (PLC-5).....	60
Troubleshooting Tips.....	63
BICN Error Codes.....	64
Data Sheet	65
BICN EDS File.....	67

Introduction

Introduction:

The BICN module is a single board ControlNet® solution for Automatic Identification. The BICN module integrates BALOGH'S Passive Radio Frequency Identification Technology and the ControlNet® architecture into one field mountable enclosure. The BICN module is designed to manage two BALOGH Transceiver channels and allows the user to pass TAG data across a ControlNet® network with a simple set of instructions.

The BICN is equipped with 10 LED indicators, for field diagnostics. Other features include flash upgrade capability via the unit's RS-232 flash port, a Network Access Port or NAP port, which provides a bi-directional electrical interface for programming, maintenance, and monitoring of I/O devices. The BICN also supports redundant media for the option of installing a second cable between nodes.

Some of the features of the module are as follows:

- Field mountable enclosure
- Ten status LEDs
- Supports (2) Transceiver channels
- Baud rate: 5 Mbits/sec
- DIP switch selectable Network Address
- Quick connectors for all field wiring attachments
- Supports redundant media
- 1 NAP port (network access port)
- Flash upgradeable

Network Topology

The BICN supports redundant media. This is an optional network configuration that allows for a second segment of cable to be installed between nodes using the Channel B network connection. With redundant media, nodes send identical signals on two separate segments. The receiving node continuously evaluates the signal's quality and selects the better cable to receive the next message on.

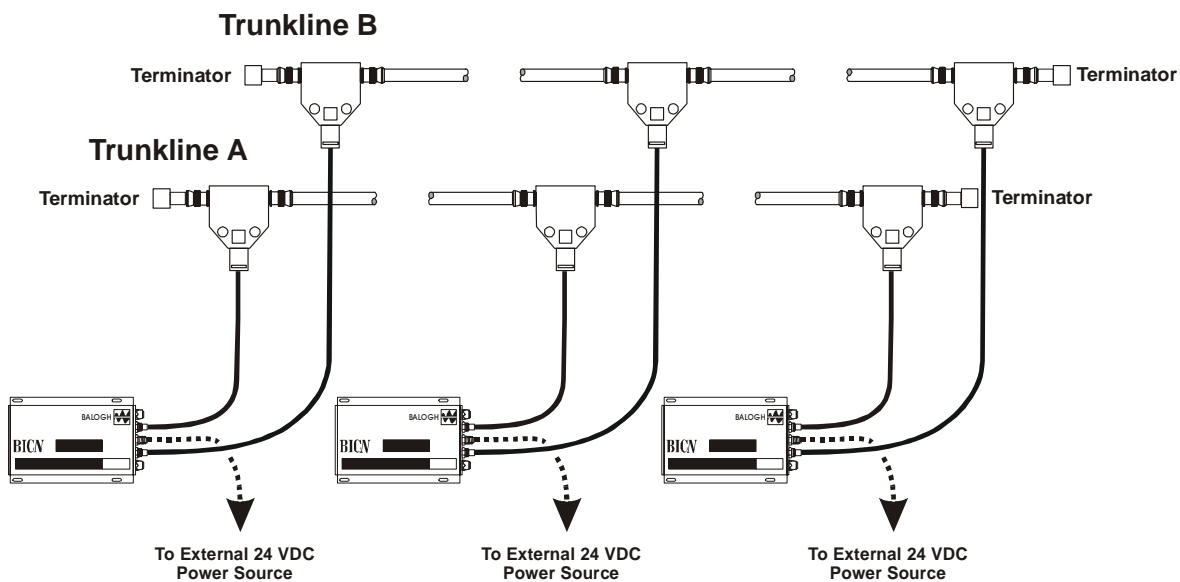

Related Hardware and Software

For the purposes of developing this manual the following hardware and software, available separately from Rockwell Automation, was used:

Hardware

1. 1756-CNB/B F/W Rev 2.24
2. 1756-L1/A F/W Rev. 10.23
3. 1756-PA 72/B
4. 1756-A7/B

ControlNet[®] Communications Bridge
Logix 5550 Processor Unit
Power Supply
7 slot Chassis

Software

5. RS Logix 5000 Version 10.00.00
6. RSNetworx for ControlNet V 3.23.00 Build 11

Mechanical Specifications:

The BICN is housed in an extruded aluminum enclosure. Each end of the enclosure is capped and sealed by a gasket. All connectors that enter the enclosure are rated IP-67.

Dimensions:

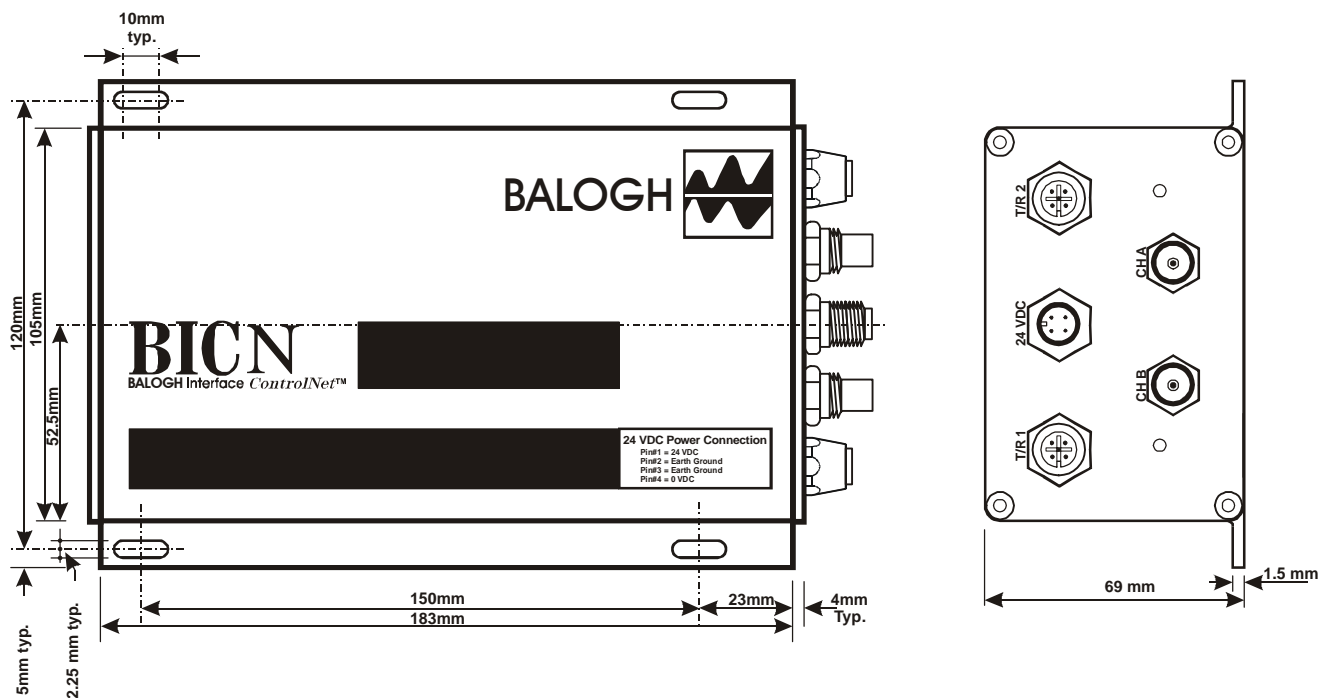

Indications that use each LED independently

Active / error channel LED	Indication
Flashing Red-Green	Bad network configuration
Flashing Red-Off	Cable fault or not connected. (Broken cable, redundancy warning, etc.)
Flashing Green-Off	Temporary network errors. (Bad MAC frame, screeners not programmed, modem not on-line, etc.)
Green	Channel OK
Off	Channel disabled



Green Operation in Progress LED

For this state:	LED is:	To indicate:
Command in Progress	On	Executing Command
No Command in Progress	Off	Idle: No Command Pending

Green TAG Present LED

For this state:	LED is:	To indicate:
TAG Present	On	TAG is in the Transceiver Transmission Zone
TAG Absent	Off	TAG is not within the Transceiver Transmission Zone

Red Channel Status LEDs

For this state:	LED is:	To indicate:
Channel detects fault	On	Transceiver/TAG fault
Channel operational	Off	Transceiver/TAG is operational

Green Unit Power LEDs

	LED is:	To indicate:
For this state:	On	Power is provided to unit
	Off	Power is not provided to unit

DIP Switches

DIP Switches:

The BICN is equipped with one bank of eight DIP switches, which are located under the top cover of the enclosure behind the status LEDs. These DIP switches are used to assign the Network Address.

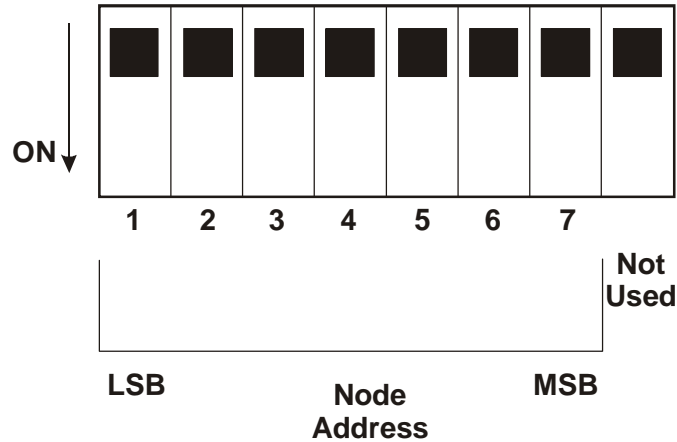

Network Address:

The Network Address DIP switches are used to assign a unique network address, which is an integer identification value assigned to each Node on ControlNet[®]. This value distinguishes a Node among all other Nodes on the same link. The DIP switches are labeled 1 through 7, with the most significant switch to the far left side.

The range of values is from 0 to 99 (Binary). The following table illustrates the range of Network Address settings:

Note: 0= Off, 1= On

DIP 1	DIP 2	DIP 3	DIP 4	DIP 5	DIP 6	DIP 7	NODE ADDRESS
0	0	0	0	0	0	0	00
1	0	0	0	0	0	0	01
0	1	0	0	0	0	0	02
-	-	-	-	-	-		-
-	-	-	-	-	-		-
1	1	0	0	0	1	1	99

Data Rate

Data Rate:

Data rate is fixed at 5 M bits/second

Example DIP Switch Settings:

The following example depicts the DIP switch settings for Node Address 76:

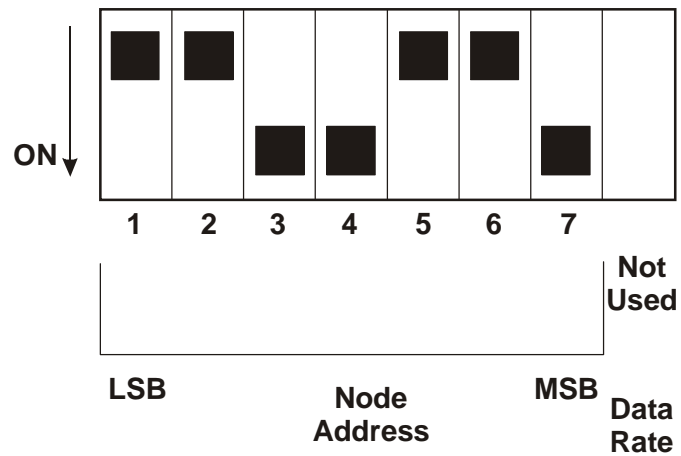

Connections

Connections:

- All connections to the BICN are made through quick connectors:
- 2 - 5 pin female connectors for Transceiver connections
- 2 - 75 ohm BNC connectors
- 1 - 4 pin male connector for 24 VDC power connection

BICN Connectors Bottom View:

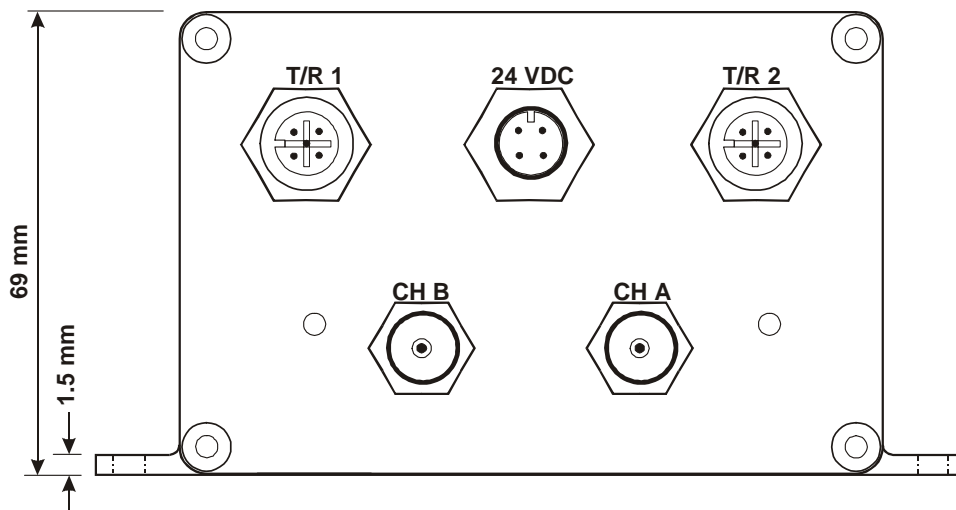

Connection Pinouts and Mating Types:

Transceiver Connection Pinouts and Mating Types:

The following table lists the connector types that are specified for connecting a Transceiver to the BICN Module. The part numbers listed below are available from BALOGH. Please consult the BALOGH Product Guide for complete listing. Cables must be purchased separately.

M-F/EXT/*M	Integrated male/female patch cable assembly available in lengths of 2 meters, 5 meters, 10 meters, 15 meters, and 20 meters. Other lengths available by special order.
------------	--

The drawing below depicts the wiring schematic used when connecting a FC/Male connector to the BICN Module.

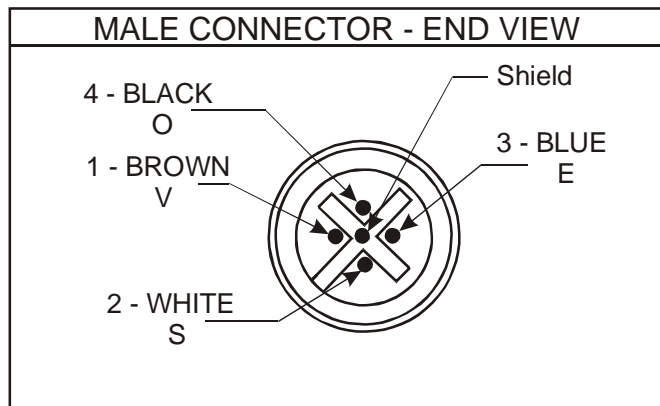

Power Connections

Power Connection Pinouts and Mating Types:

The following table lists the connector types that are specified for connecting power to the BICN Module. The part numbers listed below are available from BALOGH. Cables must be purchased separately.

Please consult the BALOGH Product Guide for complete details.

SEF-ST/*M	Integrated female connector and cable assembly available in lengths from 2 meters to 50 meters.
FC/Female	Female field connector housing for field wiring of separate cable.

The drawing below depicts the wiring schematic used when connecting an FC/Female connector to the BICN Module.

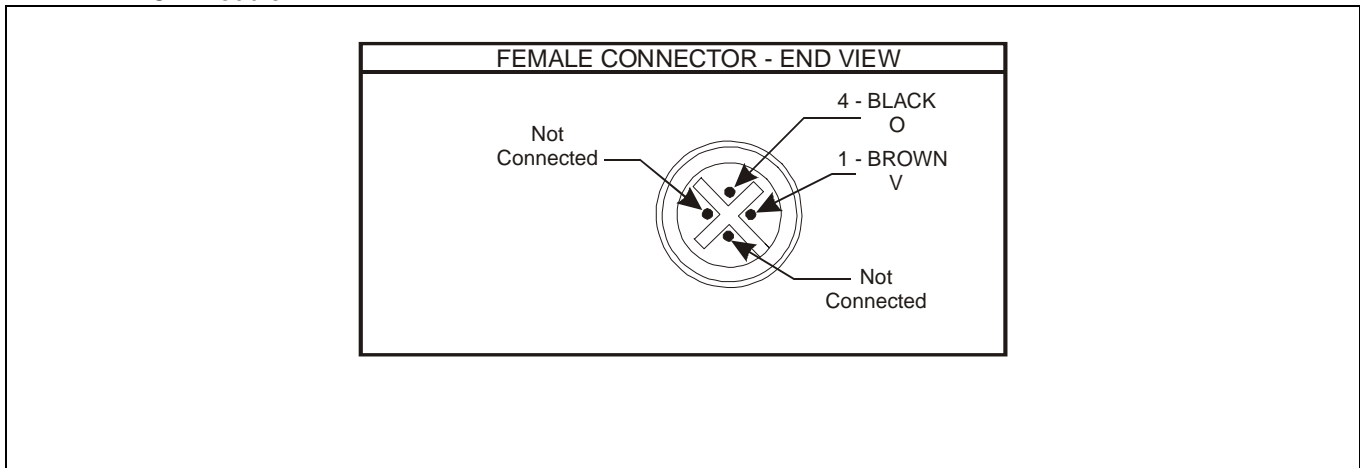

BICN Configuration on a ControlNet[®] Network

BALOGH

7699 Kensington Court
Brighton, MI 48116-8561
(248) 486-7343

I/O Sizes and Network Parameters

The following is a brief discussion of the network parameters settings required when a BICN module is scheduled on a ControlNet Network and the influence these settings may have upon the BICN modules performance.

Input Connection size:

The Input Size is variable between 2 and 32 words. The Input size should be large enough to encompass the modules Dynamic Status and Operational Status words and if necessary to include the Fixed Code Read Results Field if the Fixed Code only operating mode is utilized. This data is included in the Scheduled Bandwidth field of the network update time.

Output Connection size:

The Output Size is variable between 1 and 32 words. A minimum value of 1 is required to pass the Module Control Word to the BICN. Words 2 through 32 are reserved for future use. This data is included in the Scheduled Bandwidth field of the network update time.

Requested Packet Interval (RPI) :

The requested packet interval is the rate at which the I/O data exchange will take place between the control device and the BICN. This interval determines how often such data as the Dynamic Status (Tag Present Bit) , Operational Status (Command Execution Bit) and Fixed Code Tag Read Data will be updated in the clients Input Address range.

The effect of this value is as follows:

If this value is too high events taking place at the BICN module may be missed. For example, if a Tag Block Read command were issued for a small amount of data from a high speed tag the change in state of a commands execution bit may be missed due to the command actually starting and completing before an I/O update occurs.

If this value is set too low the percentage of Scheduled Bandwidth utilized on the ControlNet network will increase and the Unscheduled Bandwidth available will decrease. This will impact the throughput of Unscheduled messages used by the BICN to communicate commands and data.

Node Addressing

Do not leave gaps between node addresses, in general fewer empty node addresses utilizes more of the available bandwidth. If a network will consist of multiple BICN units then the first unit should be as close to Node address 1 as possible, all additional addresses should follow in consecutive order.

For Example:

If the PLC5/ C or CNB module is node address 1 then the BICN modules should follow as node addresses 2,3,4,5 and so on with no gaps in between.

Register The EDS File

In order to use the BICN on a ControlNet network, the EDS file must first be registered. This can be accomplished using the RSNetworx for ControlNet software tool, the BALOGH bicn.eds file, and the bicn.ico file.

Under Tools, select EDS Wizard..., This will open the EDS Wizard . Click on Next.

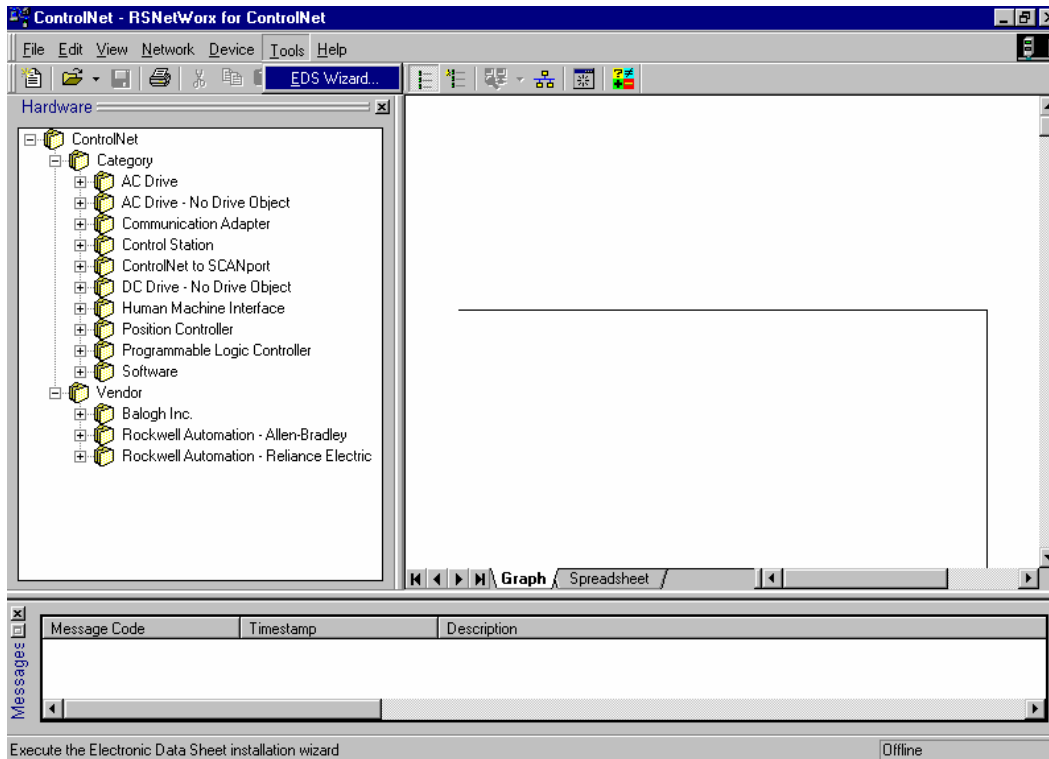

The EDS and icon file are available from BALOGH. Request a copy by emailing sales@balogh-group.com

Register The EDS File

Select the "Register an EDS file(s)," radio button and click on Next.

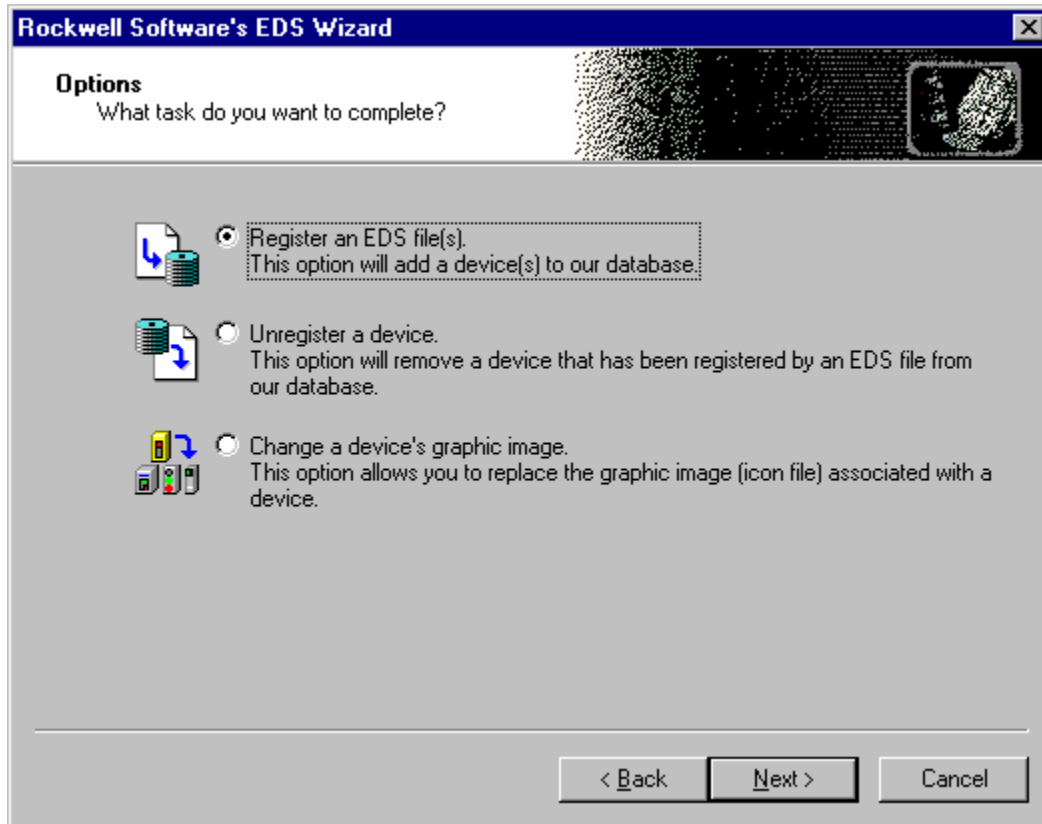

Register The EDS File

Select "Register a single file," radio button. Enter the path to the file folder that contains the bcn.eds file and the bcn.ico file. Click on Next.

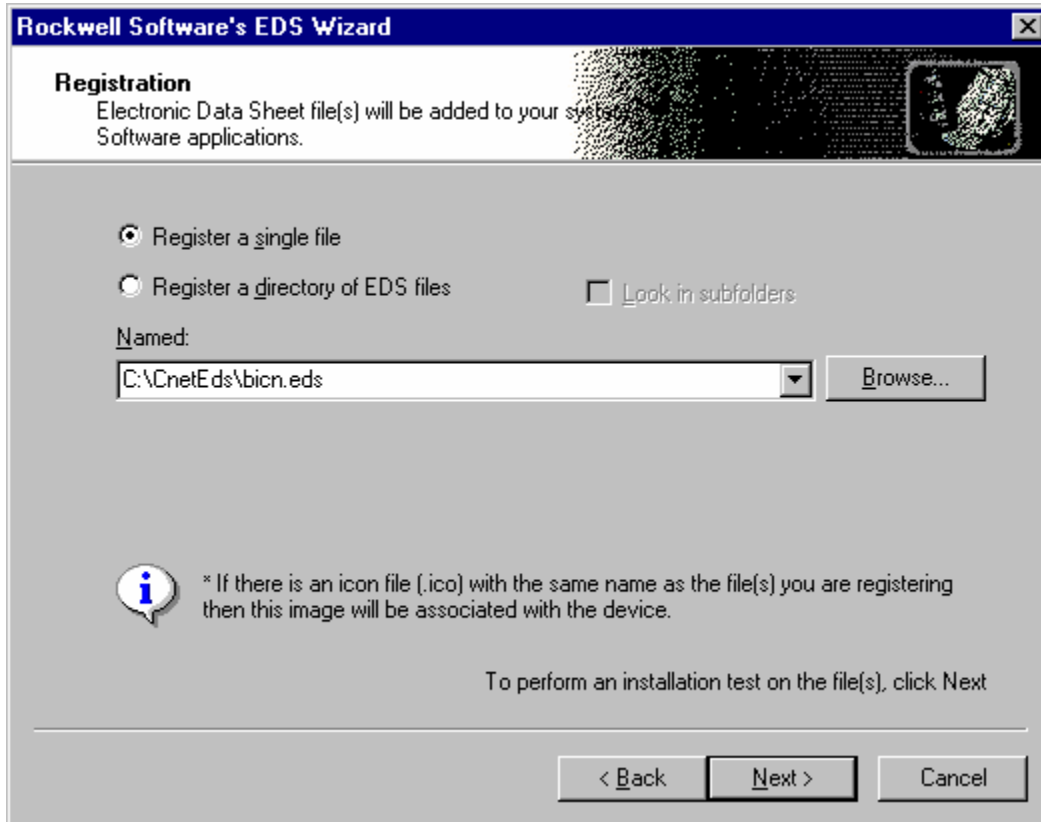

Register The EDS File

The EDS Wizard will validate the format of the EDS file, then prompt you to proceed. Click on Next.

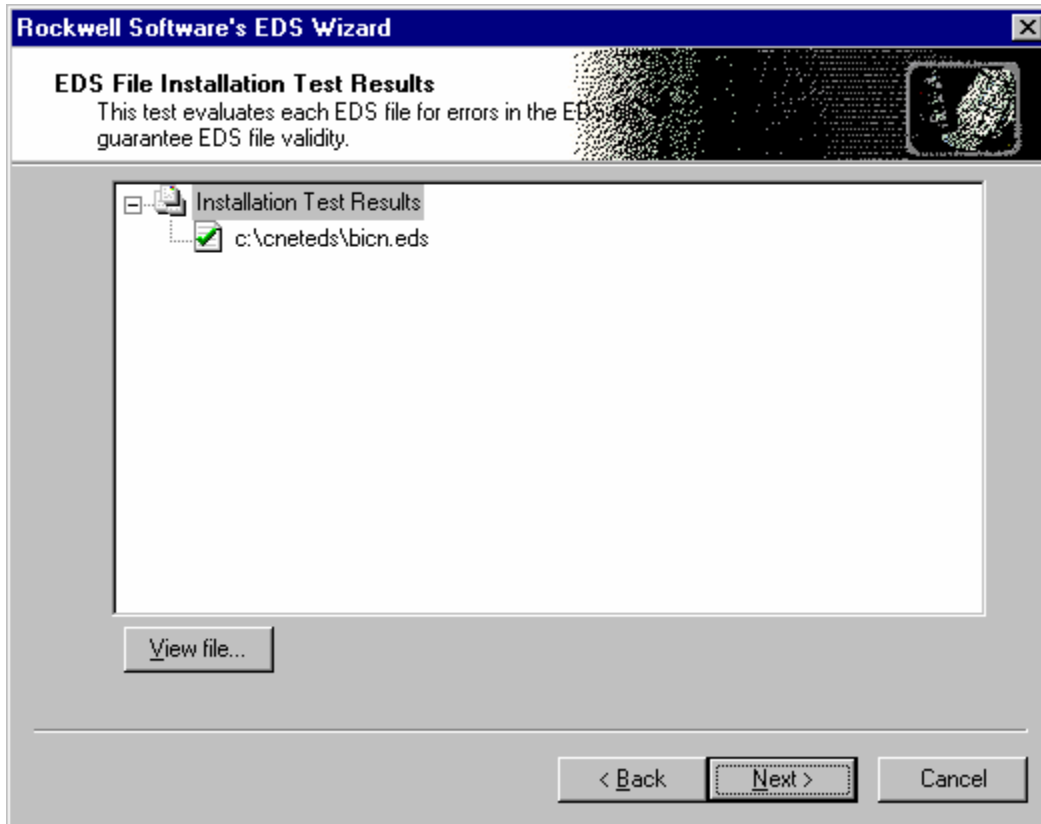

Register The EDS File

The EDS Wizard will prompt you to change the icon image. If the bcn.ico image is visible, click on Next.

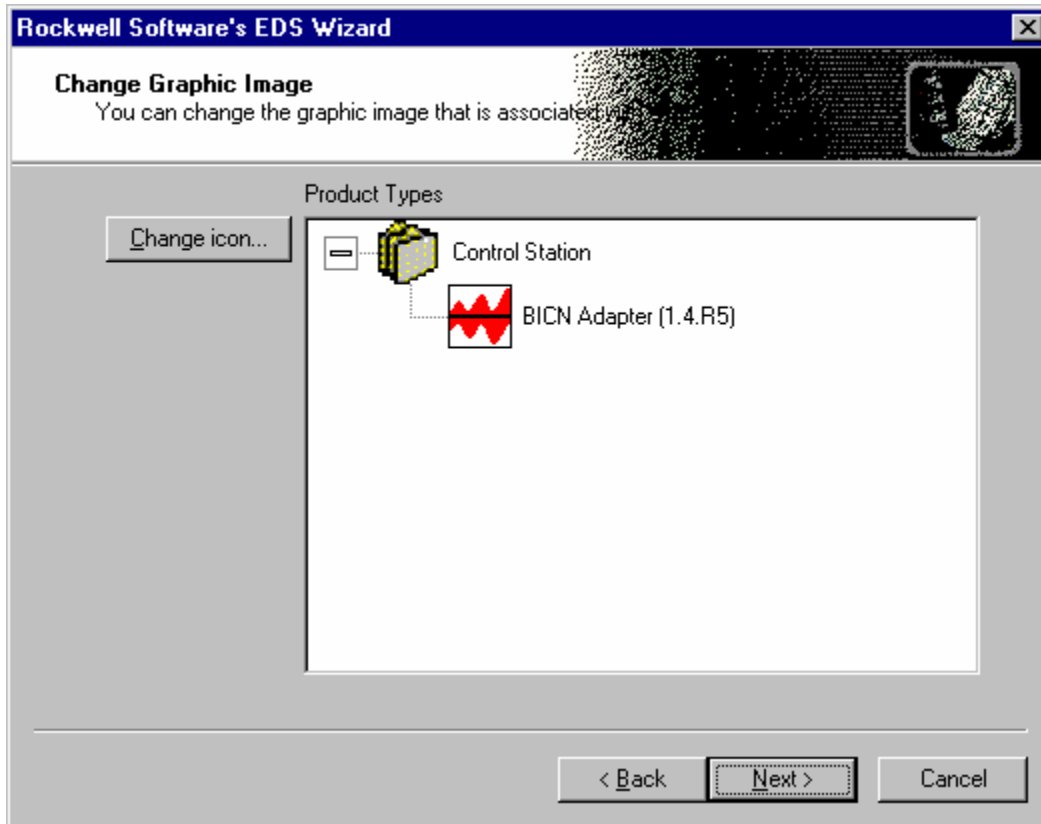

Register The EDS File

The EDS Wizard will prompt you to register the device. Click on Next.

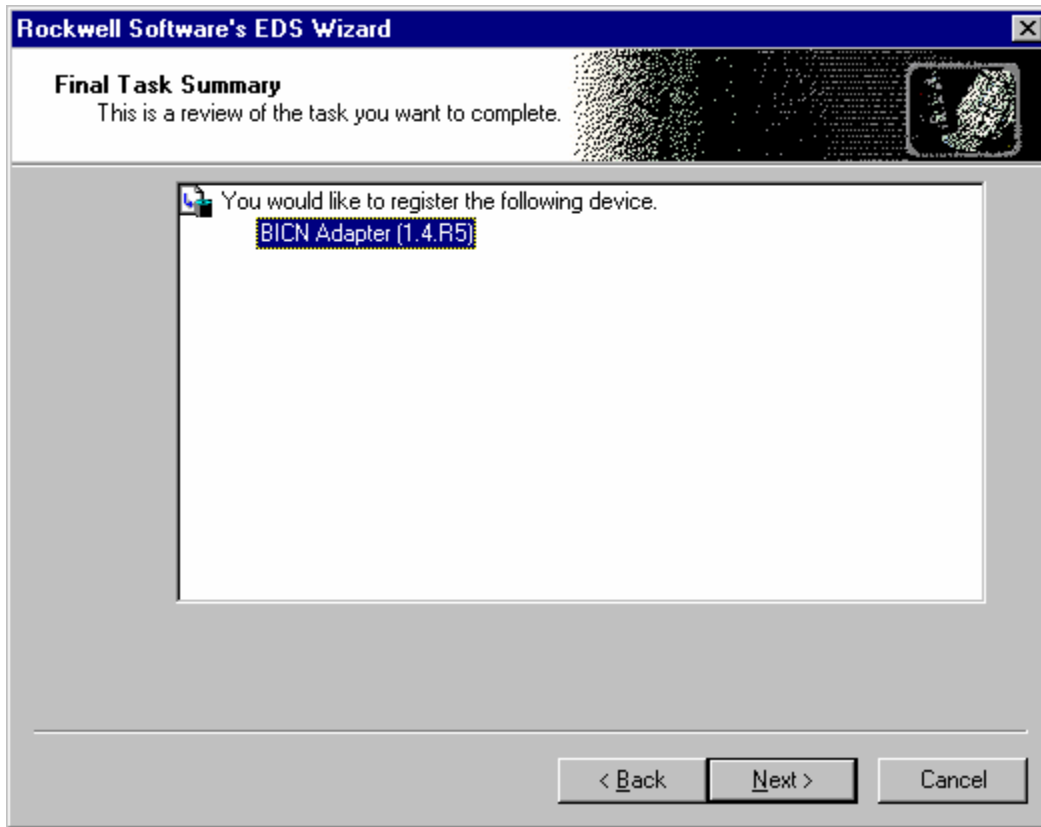

The .eds file is now be registered.

Adding a BICN to a CNB module ControlLogix platform

The following is a summary of the steps required to add a BICN to the ControlNet network and begin programming when using the ControlLogix platform

- Add the BICN module to the project's ControlNet® Bridge module under the I/O configuration tree.
- Schedule the network keeper with RSNNetWorx for ControlNet®.

The BICN module must be assigned to a ControlNet® Bridge module listed under the I/O configuration tree. To assign the BICN, locate the ControlNet® Bridge Module under the I/O configuration tree listed in the controller organizer. Right click on the module and a context sensitive menu appears, from which you can select a New Module. Use this dialogue to select and create a new module.

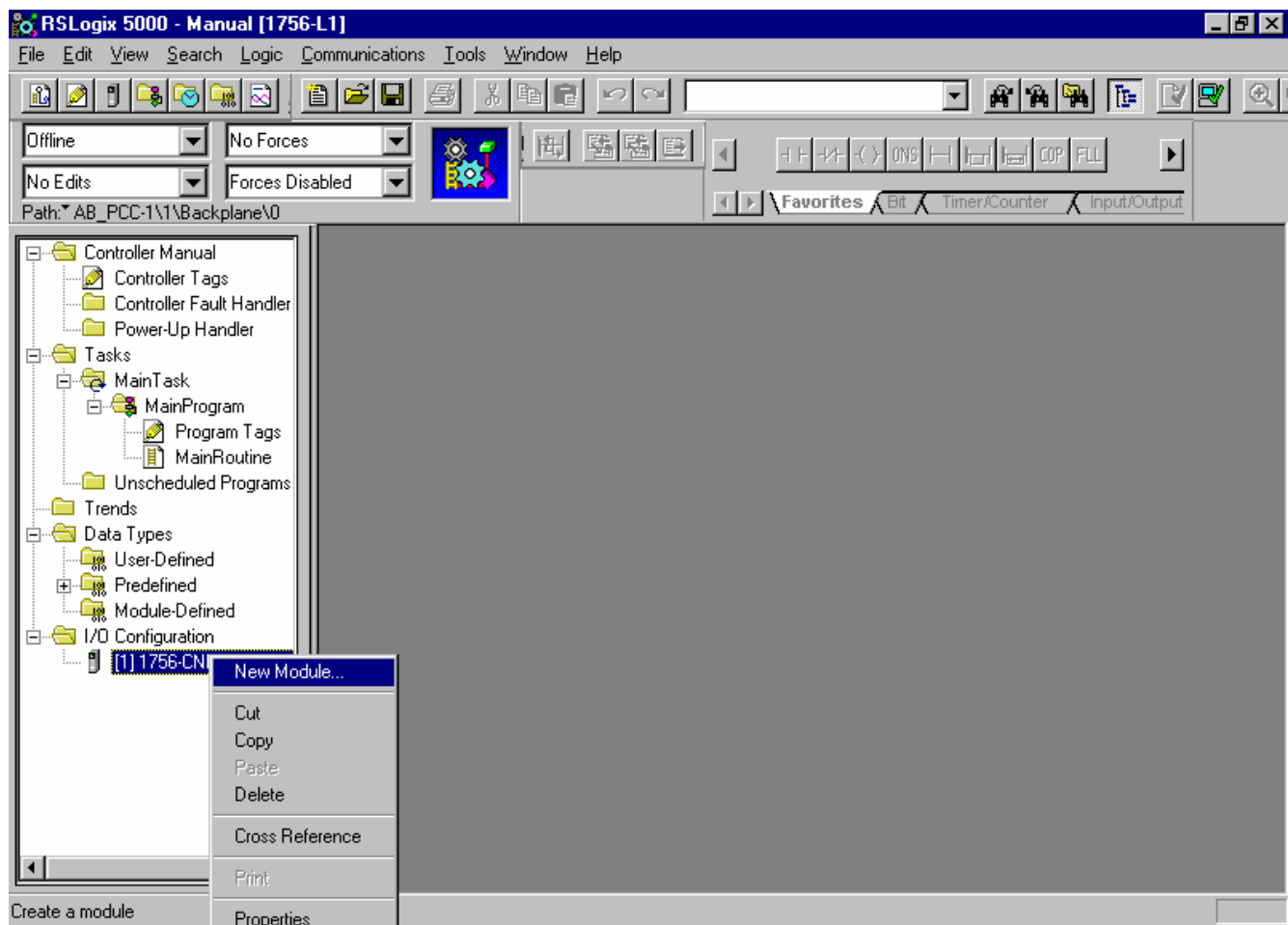

Using the Select New Module Type dialogue find the module type described as CONTROLNET® MODULE Generic ControlNet® Module and click on OK.

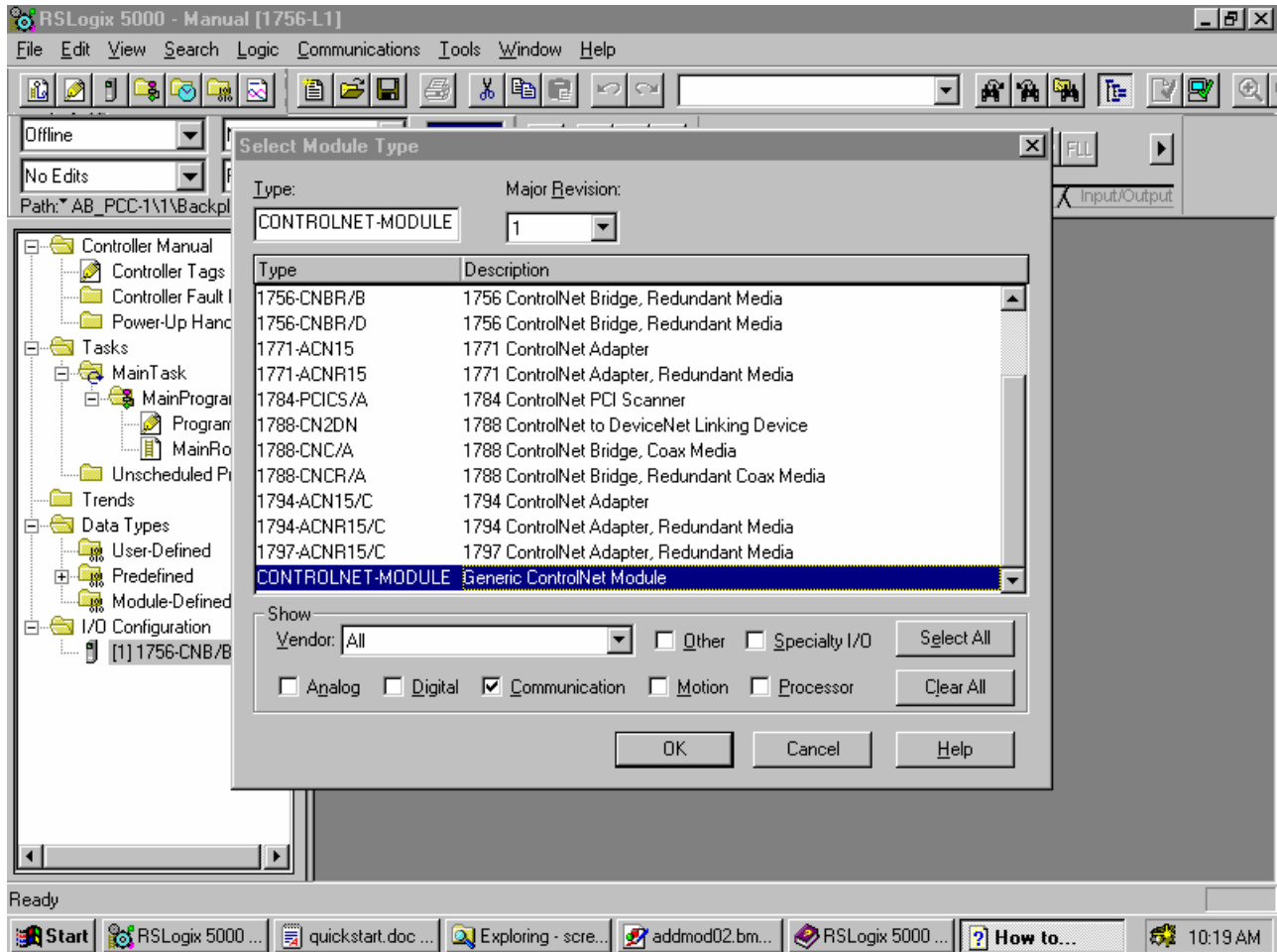

Now the Module Create Wizard will appear. Use this tab to enter the following module properties for the BICN.

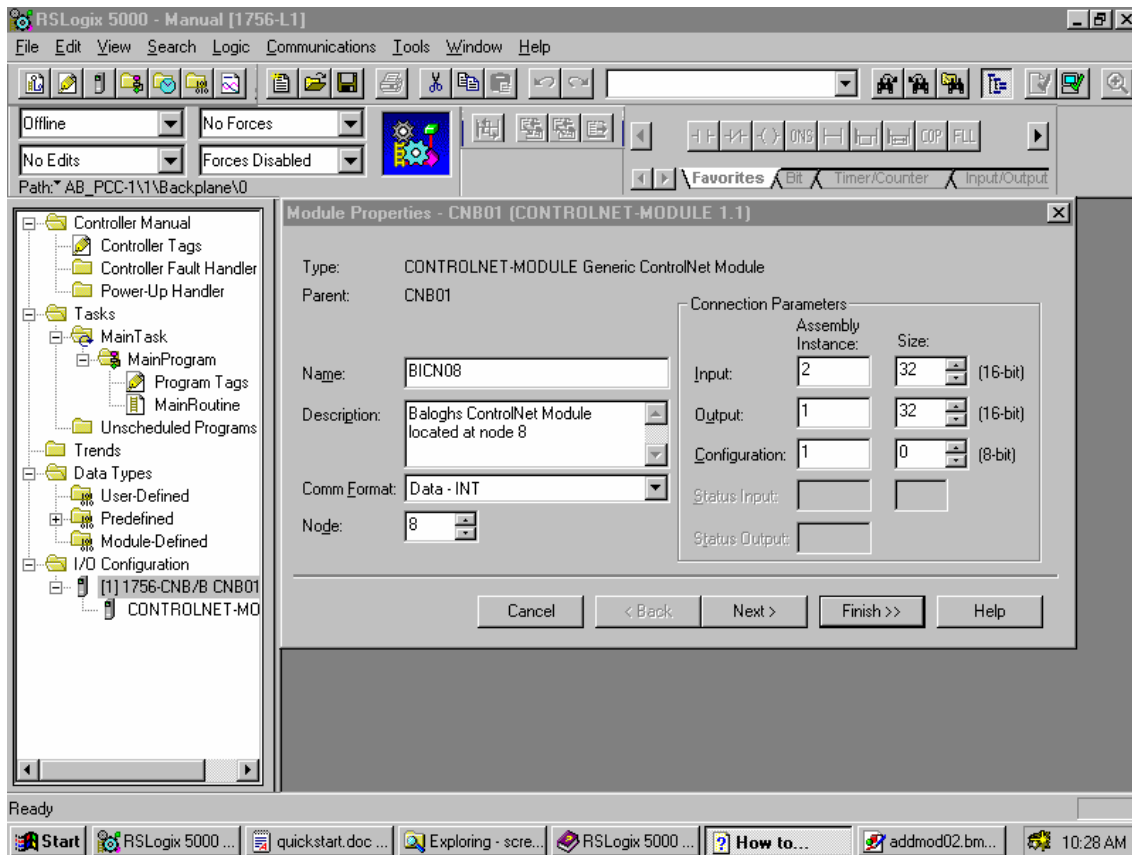

Name

Assign a name to the BICN. This name will be used in all programming references to this device.

Description

Enter a description for the module here, up to 128 printable characters are allowed.

Comm Format

You MUST select data type INT. This is the data type that will be used for all scheduled and unscheduled data representations. This data type conforms to the layout of the information presented within this manual.

Node

Enter the node number that was assigned using the DIP switch located on the BICN control board.

Connection Parameters:

Input Instance

- Assembly Instance is always 2
- Size is 32

Output Instance

- Assembly Instance is always 1
- Size is 32

Configuration Instance

- Assembly Instance is always 1
- Size is always 0

Click on Finish to assign the BICN to the network that the ControlNet bridge Module is managing

Note: Please read the section headed I/O Sizes and Network Parameters for more information regarding these parameters.

The device will appear in a fault state until the CPU has saved the schedule of the new module. This final step requires the modules I/O configuration be stored in the CPU. This is done using RSNetworkx for ControlNet®.

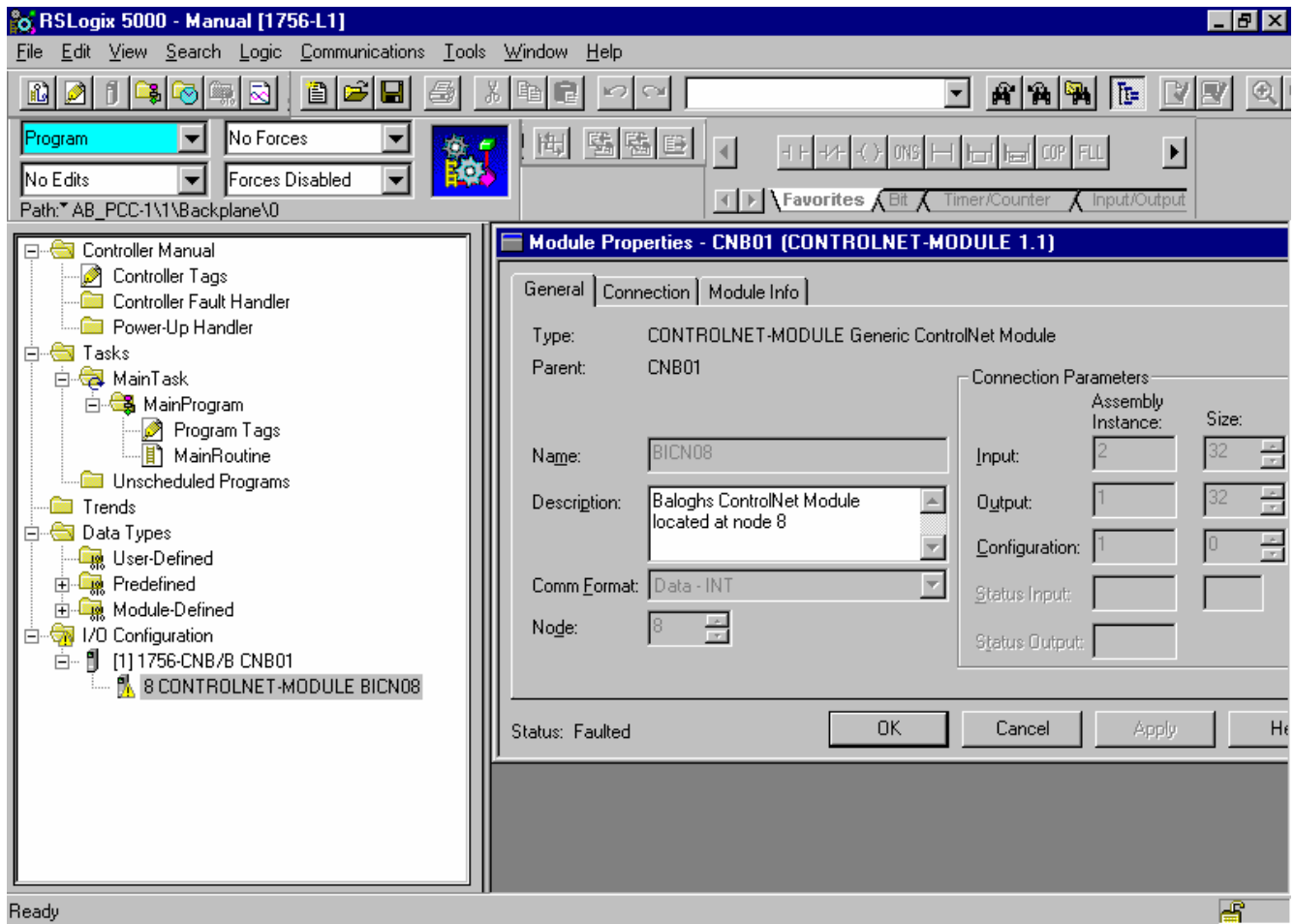

Schedule the Network

Launch *RSNetWorx* for *ControlNet*.

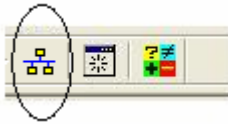

Go online by clicking on the online icon in the top tool bar. This will bring up an *RSLink* Who browse dialog. Browse to the ControlNet network as shown below and click **OK**.

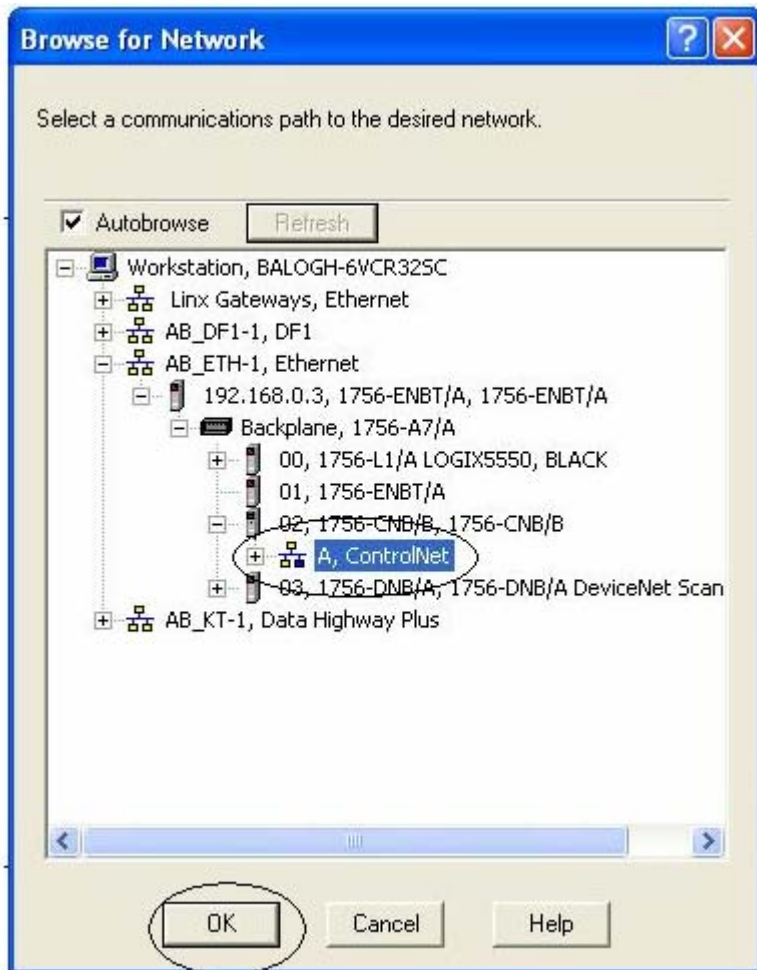

Schedule the Network

RSNetWorx will immediately go out and browse ControlNet for all of the nodes on the network and draw a graphical representation of the network. You should have something similar to what is seen below.

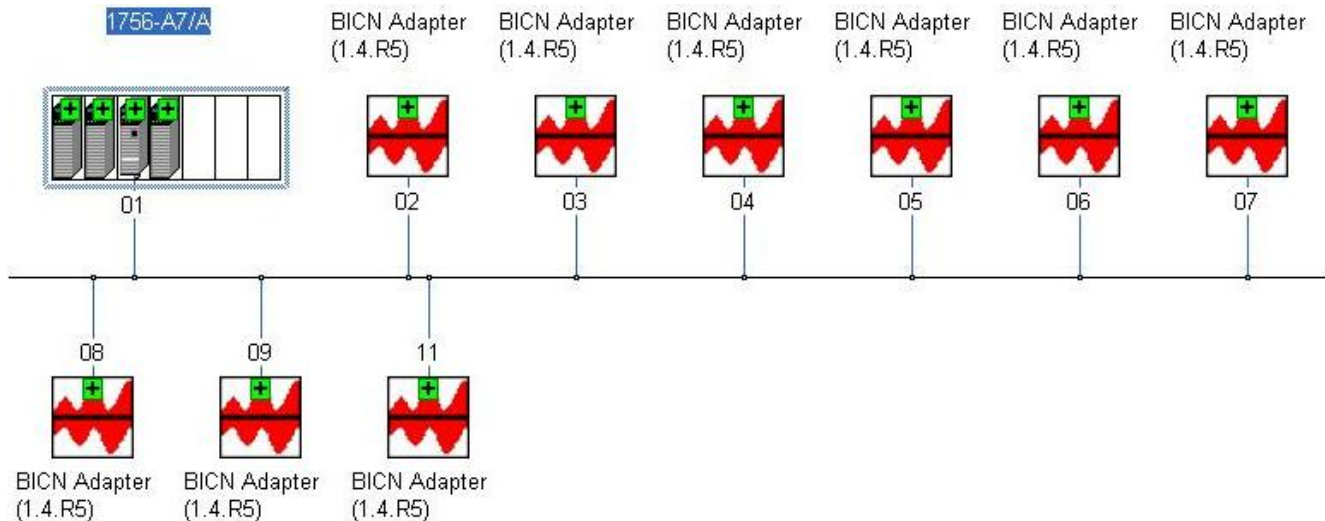

The green arrows are an indication that the node is seen on the network but is not currently in the **RSNetWorx** offline file. There are other possible symbols with different meanings. These are defined in the legend below.

Online Monitor mode (Edits Enabled checkbox not selected)

Icon	Device State	Description
No icon	Match	The identity information for the device shown in the network configuration is the same as the identity information of the physical device.
	Mismatch	The identity information for the device shown in the network configuration is not the same as the identity information of the physical device.
	Missing	The device shown in the network configuration either is offline or it is not connected to the network.
	Extra	The device shown in the network configuration does not exist in the configuration file, but it was found on the network.
	Unknown	The device shown in the network configuration exists in the offline configuration file, but the software <ul style="list-style-type: none"> cannot determine that the device exists online, or has not yet identified the device in the browse sequence
	Unable to Scan	This device appears in the network configuration, but the device can never return online state information. Therefore, the software is unable to determine if it actually exists on the network.

Schedule the Network

Enable edits in RSNetworx by clicking on the Edits Enabled box at the top right of the window.

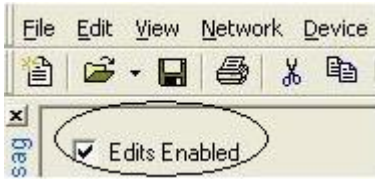

RsNetWorx will automatically go out and read the network configuration and remove the green plus signs as the online and offline files will now match.

Next the overall network parameters like the NUT, SMAX and UMAX need to be configured. This is done from the main menu **Network Properties.....** This will bring up a dialog window that will allow these parameters to be edited.

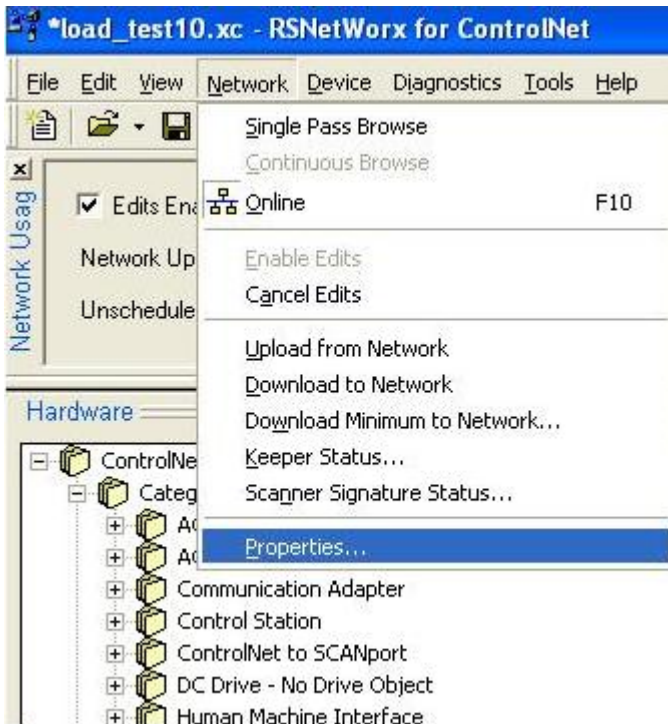

Schedule the Network

The screen capture below depicts the network properties box where the NUT ,SMAX and UMAX are configured.

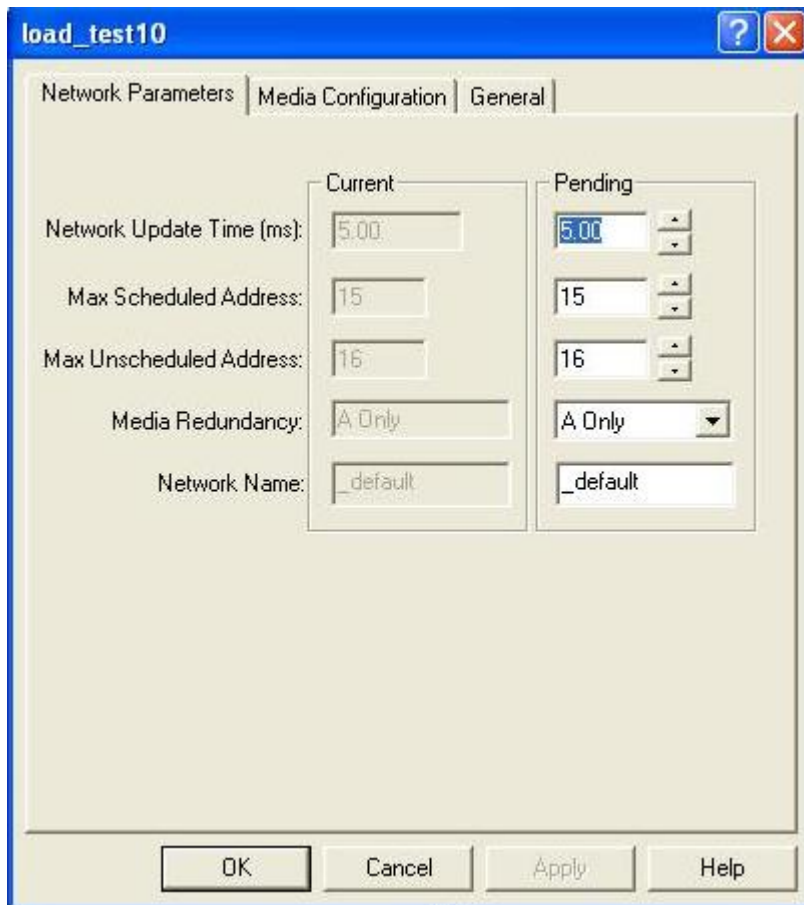

The Network Update Time is the smallest user configurable repetitive time cycle in milliseconds at which data can be sent on a ControlNet network. The range is 2 to 100 milliseconds and is configured in RSNetWorx. The NUT can not be higher than the highest device RPI on the network. A larger NUT allows for more unscheduled bandwidth. This is important when applying the BICN because the BICN module uses PLC5 Typed Read and PLC5 Typed Write commands which are transmitted during the unscheduled portion of the NUT. A larger NUT increases the chances for more BICNs to receive Command Requests and return Tag data per each NUT cycle.

SMAX (Scheduled Maximum Node) is the highest network address of a node that can transmit data within the Scheduled Bandwidth. Each BICN uses scheduled data to transmit command execution status and to set specific operating modes. SMax must be greater than or equal to the highest BICN node on a ControlNet Network.

UMAX (Unscheduled Maximum Node) is the highest network address that can use Unscheduled Bandwidth on a ControlNet network. Each BICN may use the Unscheduled Bandwidth therefore the UMAX address must always be greater that or equal to the highest BICN node on a ControlNet network.

Schedule the Network

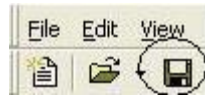

Next save the project by clicking the save icon. This will actually complete the scheduling of the network.

When the following dialog appears click on **OK**.

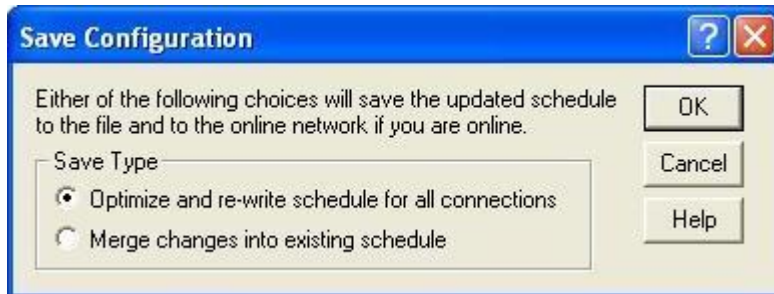

Optimize and re-write schedule for all connections:

This selection creates a new schedule based on the entire configuration. This selection reschedules the entire network and temporarily shuts down all connections in order to make the schedule change. This method of saving results in the most efficient scheduling algorithm but has the greatest impact on a running system.

Merge changes into existing schedule:

This selection includes only the changes you have made during this session into the existing schedule. This method of saving has the least impact on a running system but results in the least efficient scheduling algorithm.

This progress dialog will appear when the scheduling is taking place. This means that RSNetWorx is reading all of the connections on the network, deciding if what was programmed is valid and deciding which NUT each scheduled connection will occur in. If all criteria is passed RSNetWorx will download the schedule to the appropriate nodes.

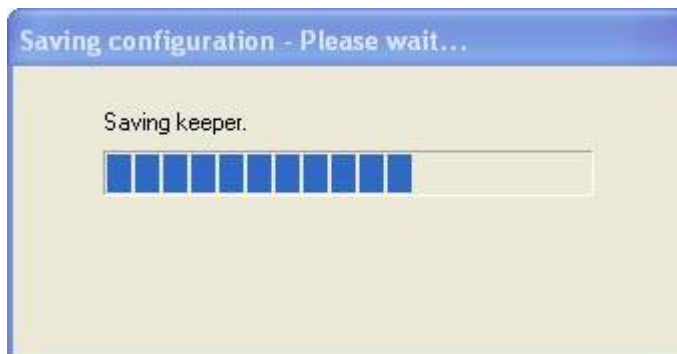

Adding a BICN to a PLC-5C platform

Launch *RSNetWorx* for *ControlNet*.

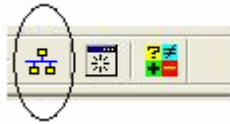

Go online by clicking on the online icon in the top tool bar.

This will bring up an *RSLink* Who browse dialog. Browse to the ControlNet network as shown below and click **OK**.

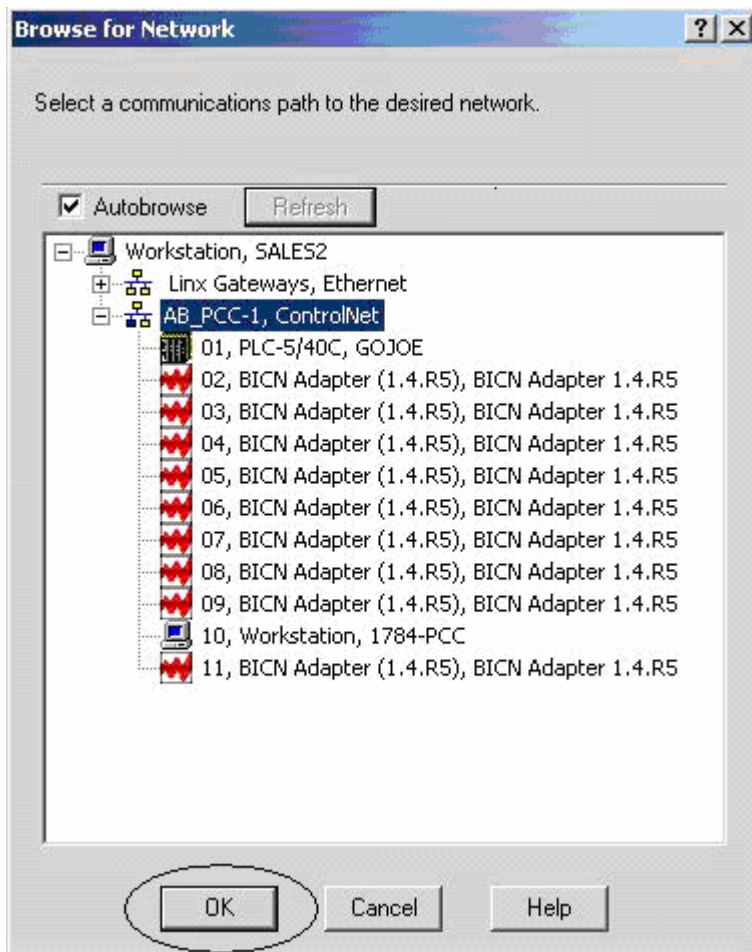

Schedule the Network

RSNetWorx will immediately go out and browse ControlNet for all of the nodes on the network and draw a graphical representation of the network. You should have something similar to what is seen below.

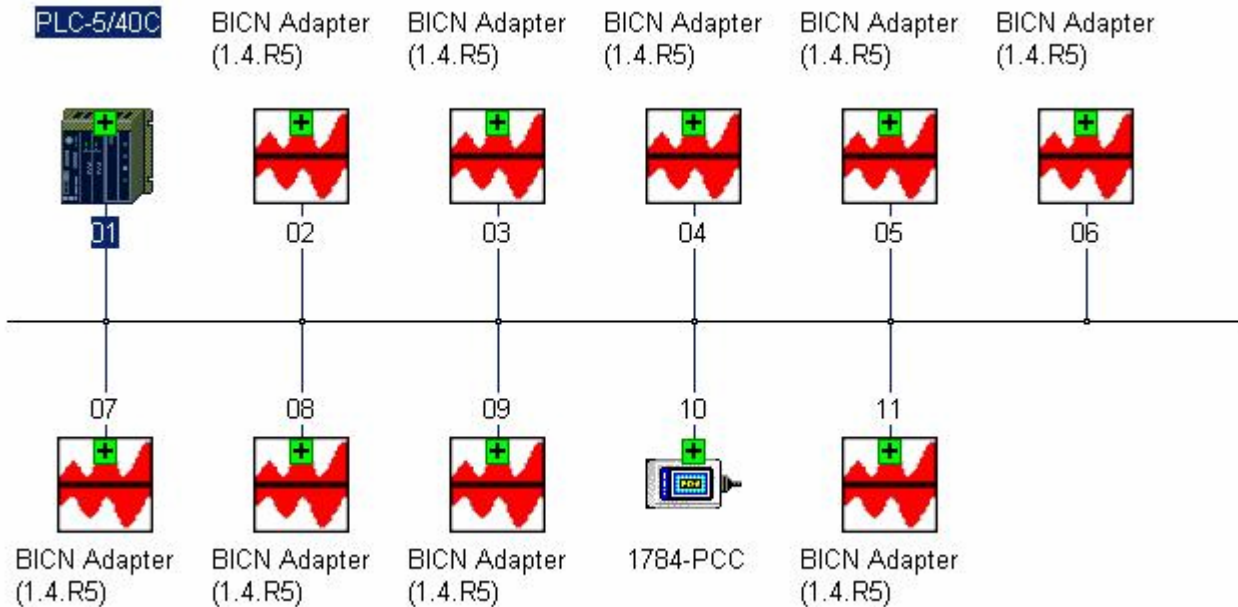

Right click on the PLC-5C icon then select the Scanlist Configuration menu item in the drop down menu.

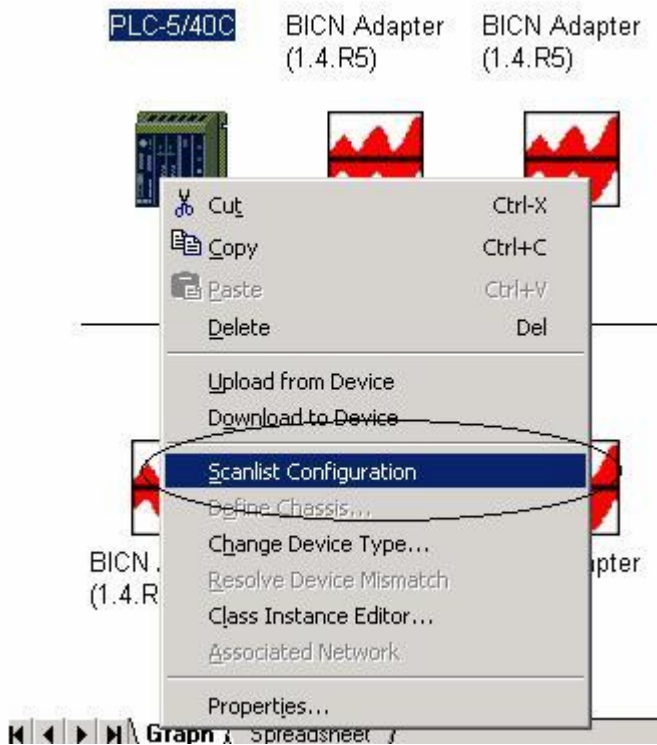

Schedule the Network

The Scanlist configuration screen will display a list of BICN devices that are present on the network. The next step is to map each BICNs I / O image into file locations utilized by the PLC 5 C. This is done by selecting the BICN to map and then right clicking. Next select the Insert Connection drop down list item.

Addr...	Slot	Parameters	Device Name	Connection Name	API(ms)
01			PLC-5/40C		
02			BICN Adapter		
03			BICN Adapter		
04			BICN Adapter		
05			BICN Adapter		
06			BICN Adapter		
07			BICN Adapter		
08			BICN Adapter		
09			BICN Adapter		
10			1784-PCC		
11			BICN Adapter		

Exclusive Owner 20.00

Schedule the Network

This will display the Connection Properties dialog. This dialog allows for the following parameters to be set.

Requested Packet Interval:

The requested packet interval is the rate at which the I/O data exchange will take place between the host and the BICN .

Input / Output connection size:

The Input Size is variable between 2 and 32 words. The Input size should be large enough to encompass the status and data words necessary to monitor the applications command execution.

The Output Size is variable between 1 and 32 words. A minimum value of 1 is required to pass the Module Control word to the BICN.

The screenshot shows the 'Connection Properties' dialog box with the 'Details' tab selected. The 'Target Information' section contains 'To Address' (02), 'Device Name' (BICN Adapter [1.4.R5]), 'To Slot', and 'Connection Name' (Exclusive Owner). The 'Communication Parameters' section has a table with 'Name' and 'Value' columns, and a 'Requested Packet Interval (ms)' spinner set to 20. The 'Addressing Parameters' section includes 'Input Size' (32 Words), 'Input Address' (N9:0), 'Output Size' (32 Words), 'Output Address' (N10:0), 'Configuration Size', 'Configuration Address' (n/a), and 'Status Address' (N11:0). There is an 'Auto Address Preferences' button and 'OK', 'Cancel', 'Apply', and 'Help' buttons at the bottom.

Note:

Please read the section headed **I/O Sizes and Network Parameters** for more information regarding these parameters.

Schedule the Network

Next save the project by clicking the save icon. This will actually complete the scheduling of the network.

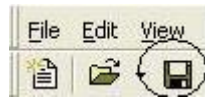

This will actually complete the scheduling of the network.

When the following dialog appears click on **OK**.

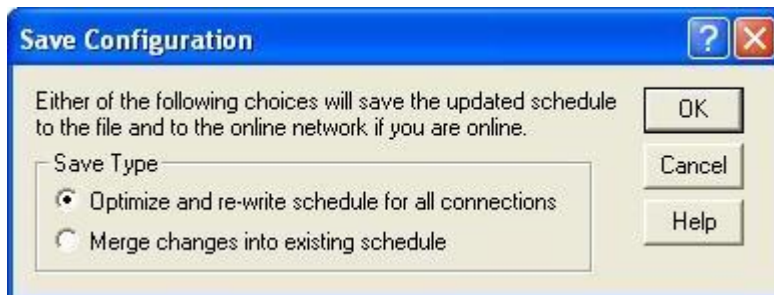

Optimize and re-write schedule for all connections:

This selection creates a new schedule based on the entire configuration. This selection reschedules the entire network and temporarily shuts down all connections in order to make the schedule change. This method of saving results in the most efficient scheduling algorithm but has the greatest impact on a running system.

Merge changes into existing schedule:

This selection includes only the changes you have made during this session into the existing schedule. This method of saving has the least impact on a running system but results in the least efficient scheduling algorithm.

This progress dialog will appear when the scheduling is taking place. This means that RSNetWorx is reading all of the connections on the network, deciding if what was programmed is valid and deciding which NUT each scheduled connection will occur in. If all criteria is passed RSNetWorx will download the schedule to the appropriate nodes.

Schedule the Network

The last step involved is to associate the new network schedule with a project in RSLogix 5. Assuming that a project already exists select the Controller Properties icon and open the associated dialogue.



Browse to the *.xc file that contains the network schedule and click on apply. Once this is done the PLC will load the ControlNet file settings into the software. All of the N files that are associated with the BICN should show up in the Data Files list.

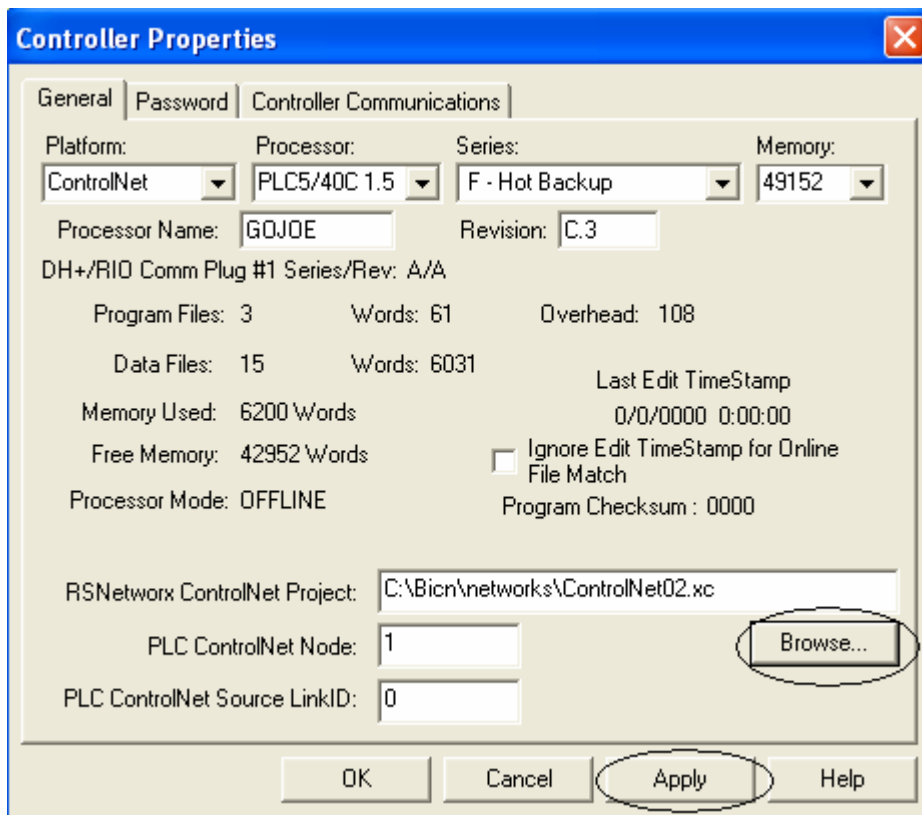

Communications Description

The BICN interface uses a combination of scheduled I/O data and unscheduled messages to communicate commands, module status, command execution status and TAG data between the CPU and the BICN module. The BICN uses three internal memory areas within its memory map to accomplish these tasks. These memory areas are referred to in this manual as the Command Buffer, Operational Status Word, and the Results Buffer. Each Command buffer has an associated Operation Status Word and Results Buffer which are used to process instruction requests, update a current command's execution status, and present the results of an operation respectively.

Command Buffers: Eight buffers, which can each process a command request.
 Operation Status Words: Eight words that indicate a command's execution status.
 Results Buffers: Eight buffers that will store data upon completion of a command.

Command Buffers:

Commands requests are issued to the BICN using unscheduled messages in the form of PLC-5 Typed Write instructions. The message instructions are directed to one of the eight Command Buffers located within the units memory map. For example, to send the BICN a Tag Block Write command, the command parameters and data would be combined into one array and designated as the source element of the Typed Write command. The Destination Element of the Typed Write Command would be the first element of one of the eight Command Buffers such a N7:128. The Command Buffers purpose is to receive the instruction parameters and TAG data if writing TAGS, validate the instruction parameters and start the execution of the command.

Operational Status:

The Operational Status word consists of eight bits of data located in the low byte of the word. These bits include the Execution Bit, TAG Memory bit, General Fault bit and specific fault indication bits. One Operational Status word is associated with each Command Buffer. This information is continuously communicated back to the host via the 32 word Scheduled data connection. When a valid instruction is received, the BICN updates the Operational Status word associated with the Command Buffer at the start of a command's execution and will set the Execution bit low (0). Upon completion of the command, this word will be updated again with the Execution bit returned high (1) and any relevant fault information is updated. The user must monitor this word to determine when a command has completed.

Results Buffers:

The Command results are retrieved from the Results Buffer using unscheduled messages in the form of PLC-5 Typed Read commands. For example, once a Tag Block Read Command has completed for Command Zone 2 a Typed Read instruction would be issued whose Source Element is N7:1280. This is the first word of data read and stored as the result of a tag read operation at Command Zone 2. The Results Buffer is the storage area for TAG read data, and will hold a copy of the last data written to the TAG in the case of a write command request.

Command Buffer	Operational Status	Result Buffer
Command Zones	Command Execution Results	Result Zone
N7:128 Command Zone 1	ModuleName:I. Data[04] Op. Status Result Zone1	N7:1152 Result Zone 1
N7:256 Command Zone 2	ModuleName:I. Data[05] Op. Status Result Zone2	N7:1280 Result Zone 2
N7:384 Command Zone 3	ModuleName:I. Data[06] Op. Status Result Zone3	N7:1408 Result Zone 3
N7:512 Command Zone 4	ModuleName:I. Data[07] Op. Status Result Zone4	N7:1536 Result Zone 4
N7:640 Command Zone 5	ModuleName:I. Data[08] Op. Status Result Zone5	N7:1664 Result Zone 5
N7:768 Command Zone 6	ModuleName:I. Data[09] Op. Status Result Zone6	N7:1792 Result Zone 6
N7:896 Command Zone 7	ModuleName:I. Data[10] Op. Status Result Zone7	N7:1920 Result Zone 7
N7:1024 Command Zone 8	ModuleName:I. Data[11] Op. Status Result Zone8	N7:2048 Result Zone 8

Communications Description

The following is a step by step description of how the command response sequence between the host device and the BICN module is carried out.

Command Execution Sequence

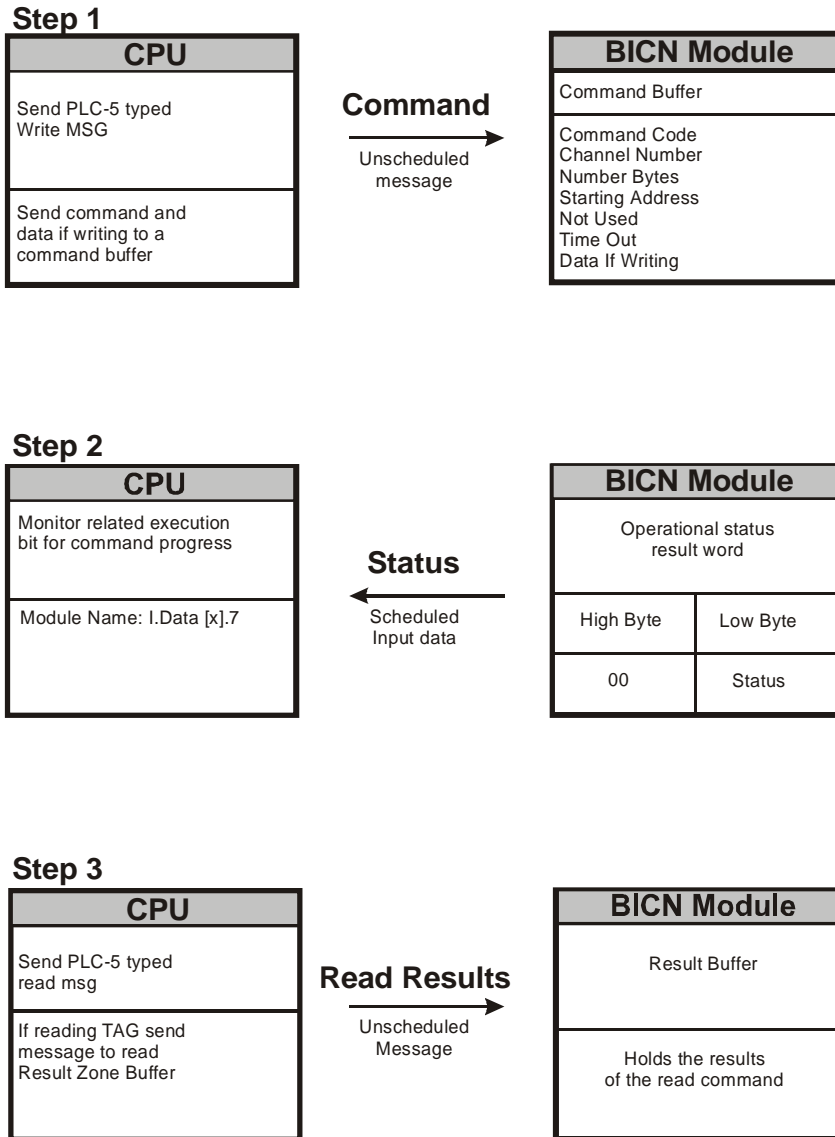

Scheduled Data

Scheduled data is represented in the 32 word I/O image that is defined when the module is assigned to a network. The format the data takes depends on the platform the BICN module is working on.

When the BICN is used on a 1756 platform references to the scheduled data will take the following form.

- ModuleName:x.Data[n].b

ModuleName is the name assigned to the BICN with the Module Create Wizard.

x will be either I, for input, or O for output, and defines the scheduled data image being referenced.

n will be a decimal number between 0 and 31 and indicates the offset into the data image table.

b will represent a bit offset from 0 to 15 that indicates a specific bit within the data word.

For example BICN08:O.Data[0].0

This reference is to the BICN module named BICN08 and is directed toward the scheduled data output image Word 0 bit 0. Which happens to be the RUN enable bit for the BICN module.

When the BICN is used on a PLC 5 – C platform references to the scheduled data will take the form of the file type they are mapped to.

Scheduled Data Input Image

The scheduled data input image consists of 32 words of data that are always defined as INT's. These fields are continuously updated as part of the scheduled data transfer on the ControlNet[®] Network. These fields contain information regarding the state of the module, the current status of each Transceiver connection, the execution status of each command field, and a special purpose data zone for Fixed Code mode of operation.

Scheduled Data Input Image 1756 platform

Memory Map for BICN Scheduled Input Data Image	
ModuleName:l. Data[00]	Reserved
ModuleName:l. Data[01]	Reserved
ModuleName:l. Data[02]	Module Status
ModuleName:l. Data[03]	Dynamic status
Operation Status Results Words	
ModuleName:l. Data[04]	Op. Status Result Zone1
ModuleName:l. Data[05]	Op. Status Result Zone2
ModuleName:l. Data[06]	Op. Status Result Zone3
ModuleName:l. Data[07]	Op. Status Result Zone4
ModuleName:l. Data[08]	Op. Status Result Zone5
ModuleName:l. Data[09]	Op. Status Result Zone6
ModuleName:l. Data[10]	Op. Status Result Zone7
ModuleName:l. Data[11]	Op. Status Result Zone8
Fixed Code Read Results Field	
ModuleName:l. Data[12]	Fixed Code Channel Read Channel 1
ModuleName:l. Data[13]	Fixed Code Channel Read Channel 1
ModuleName:l. Data[14]	Fixed Code Channel Read Channel 1
ModuleName:l. Data[15]	Fixed Code Channel Read Channel 1
ModuleName:l. Data[16]	Fixed Code Channel Read Channel 2
ModuleName:l. Data[17]	Fixed Code Channel Read Channel 2
ModuleName:l. Data[18]	Fixed Code Channel Read Channel 2
ModuleName:l. Data[19]	Fixed Code Channel Read Channel 2
ModuleName:l. Data[20]	Reserved
*****	*****
*****	*****
*****	*****
ModuleName:l. Data[31]	Reserved

Module Status Word

Word 2 Scheduled Data

Module Status Word Definition

The Module Status word provides feedback for events requested using the control word.

Bits 15-8	Bit 7	Bit 6	Bit 5	Bit 4	Bit 3	Bit 2	Bit 1	Bit 0
Reserved	Reset Ch 2	Reset Ch 1	Swap	Reserved	Fixed Code Mode	Invalid Code	Invalid Channel	Run/Stop

Module Status	bit 0	Run/Stop	Copy of the RUN/STOP bit from the control word
	bit 1	Invalid Channel	When true (1) indicates that the user entered an invalid Transceiver channel number.
	bit 2	Invalid Code	When true (1) indicates that the user has sent an invalid command code
	bit 3	Fixed Code Mode	Copy of the Fixed Code Mode bit from the control word
	bit 4	Reserved	Always zero
	bit 5	Swap Bit	Copy of the Swap Bit from the control word
	bit 6	Reset CH1	Copy of the Reset Channel 1 bit from the control word
	bit 7	Reset CH2	Copy of the Reset Channel 2 bit from the control word
	bit 8 - 15	Reserved	Always zero

NOTE:

You must put the PLC into program mode then back into run mode after you put the unit into Fixed Code Mode.

Dynamic Status Word

Word 3 Scheduled Input Data

Dynamic Status Word

The dynamic status is a continuously updated word that contains the status of each Transceiver channel regardless of the execution state of the channel. This data is useful for monitoring the state of each Transceiver channel and determining the presence or absence of a TAG without the need for an externally hard-wired input.

Dynamic Status Word 1				
	Bit		Name	Description
C H A N N E L 1	0	ModuleName:l. Data[03].0	Specific Fault (bits 0-3)	Description of Specific Fault
	1	ModuleName:l. Data[03].1	Specific Fault (bits 0-3)	Description of Specific Fault
	2	ModuleName:l. Data[03].2	Specific Fault (bits 0-3)	Description of Specific Fault
	3	ModuleName:l. Data[03].3	Specific Fault (bits 0-3)	Description of Specific Fault
	4	ModuleName:l. Data[03].4	General Fault	1 = Fault or Timeout
	5	ModuleName:l. Data[03].5	TAG Present	1 = TAG Present
	6	ModuleName:l. Data[03].6	Low Battery	1 = Battery Low *
C H A N N E L 2	7	ModuleName:l. Data[03].7	Execution Status	1 = Execution Complete
	8	ModuleName:l. Data[03].8	Specific Fault (bits 0-3)	Description of Specific Fault
	9	ModuleName:l. Data[03].9	Specific Fault (bits 0-3)	Description of Specific Fault
	10	ModuleName:l. Data[03].10	Specific Fault (bits 0-3)	Description of Specific Fault
	11	ModuleName:l. Data[03].11	Specific Fault (bits 0-3)	Description of Specific Fault
	12	ModuleName:l. Data[03].12	General Fault	1 = Fault or Timeout
	13	ModuleName:l. Data[03].13	TAG Present	1 = TAG Present
	14	ModuleName:l. Data[03].14	Low Battery	1 = Battery Low *
	15	ModuleName:l. Data[03].15	Execution Status	1 = Execution Complete

* Not applicable to the battery-less Read/Write series of TAGS.

NOTE:

When reading the "OF" style Fixed Code TAG, this bit is used to indicate that the new TAG data read is different from the last TAG data read.

Specific Fault Codes:

The following table of fault codes is valid when the general fault bit of the status result is set to one.

Specific Error Description	
Fault Code	Meaning
01 Hex	Invalid Data Length
05 Hex	Internal channel hardware fault
0B Hex	Invalid TAG address requested
0C Hex	Transceiver fault
0E Hex	TAG memory fault
0F Hex	TAG dialogue fault

Operation Status Result Word

Input Image Words 4-11

Operational Status Result Words

This word provides the status of the current command that has been executed. This word includes the Command Execution Status bit, which is used for verifying the execution of a command. This bit is initially high at power up and will transition low when a command has been accepted by the BICN. Upon completion of the command, it will return high. At that time, all other status bits will also be valid. The command status result is held until the execution of the next command or loss of power.

Command Status Result Word 4-11

C O M M A N D S T A T U S	Bit	Name	Description
	0	Specific Fault (bits 0-3)	Description of Specific Fault
	1	Specific Fault (bits 0-3)	“ ”
	2	Specific Fault (bits 0-3)	“ ”
	3	Specific Fault (bits 0-3)	“ ”
	4	General Fault	1 = Fault or Timeout
	5	TAG Present	1 = TAG Present
	6	Low Battery	1 = Battery Low
	7	Execution Status	1 = Execution Complete
	8 -15	Reserved	

Specific Fault Codes:

The following table of fault codes is valid when the general fault bit of the status result is set to one.

Specific Error Description

Fault Code	Meaning
05 Hex	Internal channel communications fault
0B Hex	Invalid TAG address requested
0C Hex	Transceiver fault
0E Hex	TAG memory fault
0F Hex	TAG dialogue fault or Timeout
01 Hex	Invalid Data Length

Each Operational Status Word is related to a specific Command Buffer. See table X.X

Fixed Code Read Results Field

The Fixed Code Results field is a section of the Scheduled Input Data table reserved for the Fixed Code only operating mode. This mode allows the BICN to actively scan each Transceiver channel looking for a TAG to arrive. Once a TAG appears in the zone of the Transceiver, seven bytes of data are read automatically starting at address zero, and the information is placed in the channel designated data field.

Fixed Code Mode TAG Data Placement

Input Location		TAG Data	
		High	Low
C H A N N E L 1	ModuleName:I. Data[12]	Address 1	Address 0
	ModuleName:I. Data[13]	Address 2	Address 3
	ModuleName:I. Data[14]	Address 4	Address 5
	ModuleName:I. Data[15]	00	Address 6
C H A N N E L 2	ModuleName:I. Data[16]	Address 1	Address 0
	ModuleName:I. Data[17]	Address 2	Address 3
	ModuleName:I. Data[18]	Address 4	Address 5
	ModuleName:I. Data[19]	00	Address 6

NOTE:

You must put the PLC into program mode then back into run mode after you put the unit into Fixed Code Mode.

Scheduled Data Output Image

Memory Map for BICN Scheduled Output Data Image

ModuleName:0. Data[00]	Control word
ModuleName:0. Data[01]	Reserved
ModuleName:0. Data[31]	Reserved

Module Control Word

Bit 7	Bit 6	Bit 5	Bit 4	Bit 3	Bit 2	Bit 1	Bit 0
Reset Ch 2	Reset Ch 1	Swap	Reserved	Fixed Code Mode	Invalid Code	Invalid Channel	Run/Stop

Bit 15	Bit 14	Bit 13	Bit 12	Bit 11	Bit 10	Bit 9	Bit 8
Reserved	Reserved	Reserved	Reserved	Reserved	Reserved	Disable Channel 2	Disable Channel 1

The Module control word contains bits used to enable various features of the BICN module.

Control Board	Bit	Function	Description
	Bit 0	Run/Stop	Setting this bit True (1) will place the module into RUN mode
	Bit 1	Not Used	Always set to zero
	Bit 2	Not Used	Always set to zero
	Bit 3	Fixed Code Mode	Setting this bit True (1) enables the Fixed Code Mode
	Bit 4	Reserved	Always set to zero
	Bit 5	Swap Bit	Setting this bit True (1) enables Byte Swapping of data
	Bit 6	Reset CH 1	Setting this bit True (1) will cancel any pending command at Channel 1
	Bit 7	Reset CH 2	Setting this bit True (1) will cancel any pending command at Channel 2
	Bit 8	Disable CH 1	Setting this bit True (1) will remove power from the transceiver
	Bit 9	Disable CH 2	Setting this bit True (1) will remove power from the transceiver
	Bit 10-15	Reserved	Always set to zero

NOTE:

You must put the PLC into program mode then back into run mode after you put the unit into Fixed Code Mode.

Command and Memory Summary

Command Summary

Command	Instruction	Parameter 1	Parameter 2	Parameter 3	Parameter 4	Parameter 5	Parameter 6-?
Block TAG Write	1(01h)	Channel	Number bytes	TAG Address	Not Used	Timeout	Write Data
Block TAG Read	2(02h)	Channel	Number of bytes	TAG Address	Not Used	Timeout	Not Used
Discontinuous TAG Rd	3(03h)	Channel	Not Used	Not Used	Not Used	Timeout	Not Used
Fill TAG	4(04h)	Channel	Number of bytes	TAG Address	Fill Value	Timeout	Not Used
Reset Request	5(05h)	Channel	Not Used	Not Used	Not Used	Not Used	Not Used
Discontinuous TAG Write	6(06h)	Channel	Not Used	Not Used	Not Used	Timeout	Write Data ZN1

Command Buffer

Operational Status

Result Buffer

Command Zones	Command Execution Results	Result Zone
N7:128 Command Zone 1	ModuleName:l. Data[04] Op. Status Result Zone1	N7:1152 Result Zone 1
N7:256 Command Zone 2	ModuleName:l. Data[05] Op. Status Result Zone2	N7:1280 Result Zone 2
N7:384 Command Zone 3	ModuleName:l. Data[06] Op. Status Result Zone3	N7:1408 Result Zone 3
N7:512 Command Zone 4	ModuleName:l. Data[07] Op. Status Result Zone4	N7:1536 Result Zone 4
N7:640 Command Zone 5	ModuleName:l. Data[08] Op. Status Result Zone5	N7:1664 Result Zone 5
N7:768 Command Zone 6	ModuleName:l. Data[09] Op. Status Result Zone6	N7:1792 Result Zone 6
N7:896 Command Zone 7	ModuleName:l. Data[10] Op. Status Result Zone7	N7:1920 Result Zone 7
N7:1024 Command Zone 8	ModuleName:l. Data[11] Op. Status Result Zone8	N7:2048 Result Zone 8

TAG Block Write Command

Command Code 1 (01 Hex)

This command writes a block of consecutive data to the TAG'S memory. Each command parameter will occupy one 16 bit word. The command parameters and data to be written to the TAG are sent to the BICN module in one message. The data to be written to the TAG should start at word 6 of the command array, just following the command words.

Command parameters defined:

- **Transceiver Channel Number**, which directs the command to channel one or channel two of the BICN module.
- **Number of bytes parameter**, which determines how many data bytes are written into the TAG'S memory.
- **TAG Start Address**, which indicates where the block of data will begin to be written in the TAG'S memory.
- **Timeout value**, which allows a command to be canceled after the timeout, has elapsed.

Command Format:

Word	Description	Values
0	Command code	01
1	Transceiver Channel Number	01 or 02
2	Number of bytes to write	1 to 212 bytes maximum
3	TAG Starting Address	0 to maximum allowed by TAG
4	Not Used	
5	Timeout	10 millisecond resolution 0 = Write with Wait (see pg.49)
6	First data word	Each data word represents 2 bytes of TAG memory
112	Last data word	Each data word represents 2 bytes of TAG memory

Example:

The source TAG contains the command parameters and data that are sent via the Typed Write Message instruction. The first word of the array contains the Block Write command code of 1. The next word contains the Transceiver channel number 2. This directs the command towards channel 2 of the BICN module. The next parameter is the Number of Bytes parameter and will instruct the BICN to write 12 bytes of data to the TAG Starting Address of 1000. The 12 bytes of data starts at word 6 in this example. The timeout value of zero issues the command with wait. This means that the command will remain posted at channel 2 until a TAG arrives in the zone of the Transceiver or the command is canceled with the reset command.

Source TAG: WR_CH1_CMD

	Word	Value	Type	Description
Command	0	0001	INT	Command Code
	1	0002	INT	Channel Number
	2	0012	INT	Number of Bytes to Write
	3	1000	INT	TAG Start Address
	4	0000	INT	Not Used
	5	0000	INT	Time Out
Data	6	1122	INT	Data
	7	3344	INT	Data
	8	5566	INT	Data
	9	7788	INT	Data
	10	9910	INT	Data
	11	1111	INT	Data

TAG Block Read Command

Command Code 2 (02 Hex)

This command reads a block of consecutive data from the TAGS memory. Each command parameter will occupy one 16 bit word. The command parameters and data to be written to the TAG are sent to the BICN module in one message.

Command Parameters Defined:

- **Transceiver Channel Number** directs the command to channel one or channel two of the BICN module.
- **Number of bytes parameter** specifies how many data bytes are read from the TAG'S memory.
- **TAG Start Address** specifies where the block of data will begin to be read from the TAG'S memory.
- **Timeout Value** allows a command to be canceled after the timeout has elapsed.

Command Format:

Word	Description	Values
0	Command code	02
1	Transceiver Channel Number	01 or 02
2	Number of bytes to Read	1 to 256
3	TAG Starting Address	0 to Maximum allowed by TAG (see pg.49)
4	Not Used	
5	Timeout	10 millisecond resolution 0 = Read with wait

Example:

This example shows the format of a typical Block Read Command arranged in an integer array. This command will read 12 bytes of data starting at the address of 1000 from a TAG located at Transceiver Channel 2. When the command completes the results will be placed in the Results Buffer that is associated with the Command Buffer defined in the Typed Write command. The command has a timeout value of 1 second (100 * 10ms / tic), which means that if no TAG arrives before 1 second has elapsed the Operation Status Result Word associated with the Command Buffer will be updated with an error code of 9Fh.

Source TAG: RD_CH2_CMD

Command	Value	Type	Description
	2	INT	Command Code
	2	INT	Channel Number
	12	INT	Number of Bytes to Read
	1000	INT	TAG Start Address
	0	INT	Not Used
100	INT	Time Out	

Discontinuous TAG Read Command

Command Code 3 (03 Hex)

This command allows up to 16 discontinuous blocks of data to be read from the TAG'S memory with just one command. This command is useful when segments of TAG data are scattered throughout the TAG. The maximum number of bytes that can be read for all zones combined is 128 bytes or 64 words. If less than 16 zones are required, the unused zones following the last zone should be filled with the value zero. Each command parameter will occupy one 16 bit word. The command parameters are sent to the BICN module in one message. The resulting data is placed consecutively in the Results Buffers.

Command parameters defined:

- **Transceiver Channel Number**, which directs the command to channel one or channel two of the BICN module.
- **Timeout Value**, which allows a command to be canceled after the timeout has elapsed.
- **Discontinuous Read Start Address** is the location within the TAGS memory where reading will begin.
- **Discontinuous Read Data Length** specifies the number of data bytes that will be read from the TAG.

Command Format:

Word	Description	Value
0	Command code 3 (03h)	03
1	Transceiver Channel Number (1,2)	01 or 02
2	Not used	
3	Not used	
4	Not Used	
5	Timeout	10 millisecond resolution 0 = Read with wait
6	Address Discontinuous Read Zone 1	0 to Maximum allowed by TAG
7	Length Discontinuous Read Zone 1	1 to 128 (maximum length for all zones combined cannot exceed 128 bytes) (see pg.49).
*	*	
*	*	
36	Address Discontinuous Read Zone 16	0 to Maximum allowed by TAG
37	Length Discontinuous Read Zone 16	1 to 128 (maximum length for all zones combined cannot exceed 128 bytes). (see pg.49)

Discontinuous TAG Read Command, Con't

Example:

This example shows the format of a typical Discontinuous Read Command arranged in an integer array. This command defines 3 separate read zones. Zone 1 starts at address 1 and will read 6 bytes. Zone 2 starts at address 10 and will read 8 bytes. Zone 3 starts at address 100 and will read 2 bytes. The command is directed toward the Transceiver at channel 2. The command has a timeout value of 2 seconds (200 * 10ms / tic), which means that if no TAG arrives before 2 seconds have elapsed the Operational Status Result Word associated with the Command Buffer will be updated with an error code of 9Fh.

Source TAG: DISRD_CH1_CMD

	Value	Type	Description
Command	3	INT	Command Code
	1	INT	Channel Number
	0	INT	Not Used
	0	INT	Not Used
	0	INT	Not Used
	200	INT	Time Out
Data	0001	INT	Start Address Zone 1
	0006	INT	Read Length Zone 1
	0010	INT	Start Address Zone 2
	0008	INT	Read Length Zone 2
	0100	INT	Start Address Zone 3
	0002	INT	Read Length Zone 3

TAG Fill Command

Command Code 4 (04 Hex)

The TAG Fill command is used to set a consecutive range of the TAG'S memory with a specified value. This command is useful when a TAG needs to be cleared prior to the start of a data collect cycle. Each command parameter will occupy one 16 bit word. The command parameters are sent to the BICN module in one message.

Command Parameters defined:

- **Transceiver Channel Number** directs the command to channel one or channel two of the BICN module.
- **Number of bytes parameter** specifies how many bytes will be filled in the TAG'S memory.
- **TAG Start Address** indicates where the fill operation will begin within the TAG'S memory
- **Fill Value** is the data value that will be placed in the zone defined.
- **Timeout Value** allows a command to be canceled after the timeout has elapsed.

Command Format:

Word	Description	Value
0	Command Code	04
1	Transceiver Channel Number	01 or 02
2	Number of bytes	0 to Maximum allowed by TAG (see pg. 49)
3	TAG address	0 to Maximum allowed by TAG (see pg. 49)
4	Fill value (data to write on TAG)	0 to 255
5	Timeout	10 millisecond resolution 0 = with wait

Example:

This example shows the format of a typical Fill Command arranged in an integer array. This command will fill the TAG at Transceiver channel 2 starting at TAG address 0 and fill 8189 bytes of the TAG'S memory with the value 255. The timeout value specified is 0 which means that the TAG command is issued with wait. This means that the command will remain posted until a TAG arrives or the command is canceled.

Source TAG: FILL_CH2_CMD

Command	Value	Type	Description
	4	INT	Command Code
	2	INT	Channel Number
	8189	INT	Number of Bytes to Write
	0	INT	TAG Start Address
	255	INT	Fill Value
	0	INT	Time Out

Reset Request Command

Command Code 5 (05 Hex)

The Reset Command allows for a pending TAG operation to be canceled. Upon issuing this command, any TAG operation pending at the channel specified in the Transceiver Channel Number parameter will be canceled.

Command Parameters defined:

- **Transceiver Channel Number** directs the command to channel one or channel two of the BICN module.

Word	Description	Value
0	Command Code	05
1	Transceiver Channel Number	01 or 02
2	Reserved	
3	Reserved	
4	Reserved	
5	Reserved	

Example:

This example shows the format of a typical Reset Command arranged in an integer array. This command will terminate any instruction pending at channel 1. The Operational Status Result Word associated with the Command Buffer will be updated with an error code of 9Fh once the command is canceled.

Source TAG: RESET_CH1_CMD

Command	Value	Type	Description
	5	INT	Command Code
	1	INT	Channel Number
	0	INT	Not Used
	0	INT	Not Used
	0	INT	Not Used
	0	INT	Time Out

Discontinuous TAG Write Command

Command Code 6 (06 Hex)

This command allows up to 16 discontinuous blocks of data to be written into the TAG'S memory with just one command. This command is useful when segments of TAG memory scattered throughout the TAG require updating at one time. The maximum number of bytes that can be written for all zones combined is 128 bytes or 64 words. If less than 16 zones are required, the unused zones following the last zone should be filled with the value zero. The first data field will start at word 38 of the command array and will extend to the length defined in the first Discontinuous Write zone length parameter. The next data field should immediately follow the first and so on until all requested data fields are packed. Each command parameter will occupy one 16 bit word. The command parameters are sent to the BICN module in one message.

Command parameters defined:

- **Transceiver Channel Number** directs the command to channel one or channel two of the BICN module.
- **Timeout Value** allows a command to be canceled after the timeout has elapsed.
- **Discontinuous Write Start Address** is the location within the TAGS memory where writing will begin.
- **Discontinuous Write Data Length** specifies the number of data bytes that will be written into the TAG.

Command Format:

Word	Description	Value
0	Command code	06
1	Transceiver Channel Number	01 or 02
2	Not used	
3	Not used	
4	Not Used	
5	Timeout	10 millisecond resolution 0 = Write with wait
6	Address Discontinuous Write Zone 1	0 to Maximum allowed by TAG
7	Length Discontinuous Write Zone 1	1 to 128 maximum length for all zones combined cannot exceed 128 bytes.
*	*	
*	*	
36	Address Discontinuous Write Zone 16	0 to Maximum allowed by TAG
37	Length Discontinuous Write Zone 16	1 to 128 maximum length for all zones combined cannot exceed 128 bytes.
38	This location starts Data Field of first Discontinuous TAG Write Zone	0 to 65,535
*		
*		

Discontinuous TAG Write Command, Con't

Example:

This example shows the format of a typical Discontinuous Write Command arranged in an integer array. This command defines 3 separate write zones. Zone 1 starts at address 10 and will write 2 bytes. Zone 2 starts at address 100 and will write 6 bytes. Zone 3 starts at address 120 and will write 2 bytes. The command's last address /data length field is indicated by following Zone 3 immediately with the value 0. The data to be written into the TAG'S memory starts at word 38. The first 2 words of data are placed at the location defined by Zone 1, the next 6 words are placed at the location defined by Zone 2, and the last 2 words are placed at the location defined by Zone 3. The command is directed toward the Transceiver at channel 1. The command has a timeout value of 2 seconds (200 * 10ms / tic), which means that if no TAG arrives before 2 seconds have elapsed the Operational Status Result Word associated with the Command Buffer will be updated with an error code of 9Fh.

Source TAG: DISWR_CH1_CMD

	Value	Type	Description
Command	1	INT	Command Code
	1	INT	Channel Number
	0	INT	Number of Bytes to Write
	0	INT	TAG Start Address
	0	INT	Not Used
	200	INT	Time Out
	10	INT	Start Address Zone 1
	2	INT	Start Length Zone 1
	100	INT	Start Address Zone 2
	6	INT	Start Length Zone 2
	120	INT	Start Address Zone 3
	2	INT	Start Length Zone 3
	0	INT	Start Address Zone 4 (These fields are set to zero to indicate the end of the Write Zones)
	0	INT	Start Length Zone 4
Word 38 Starts the Data Field			
Data	1122	INT	Data
	3344	INT	Data
	5566	INT	Data
	A1A2	INT	Data
	A3A4	INT	Data
	A5A6	INT	Data

Block Write Program Example (WITH 1756)

The following screen captures demonstrate how a Message instruction must be configured to send a command request to the BICN'S Command Buffer memory.

Message Configuration:

The Message Type to select is PLC5 Typed Write. The Source TAG must point to an integer array where the command parameters and data are organized. The Number of Elements parameter is the total number of words that will be transmitted to the BICN. This is determined by adding the 6 bytes, which make up the instruction, to the total number of bytes to be written to the TAG, then dividing by 2 to arrive at the total number of words. If this parameter is too small, only the values received in the message will be utilized and all missing data will be indeterminate. The Destination Element must point to 1 of the 8 Command Buffers in the BICN'S memory that is not currently being used.

The screenshot shows a dialog box titled "Message Configuration - WR_REQUEST_CH1". It has three tabs: "Configuration", "Communication", and "Tag". The "Configuration" tab is active. The fields are as follows:

- Message Type: PLC5 Typed Write (dropdown menu)
- Source Tag: WR_CH1_CMD (dropdown menu) with a "New Tag..." button
- Number Of Elements: 112 (spin box)
- Destination Element: N7:128 (text box)

At the bottom, there are radio buttons for "Enable", "Enable Waiting", "Start", and "Done" (which is selected). To the right of "Done" is "Done Length: 112". Below the radio buttons is an "Error Code:" label and a "Timed Out" checkbox. At the very bottom are buttons for "OK", "Cancel", "Apply", and "Help".

Block Write Program Example, Con't

Communication:

Use the Path parameter to assign a particular BICN module as the intended recipient of the Typed Write message. The Browse button will open the Module Browser dialogue depicted below and the target module can be chosen. The Communication Method radio box is always CIP. The Cache Connections check box is left unchecked, this option is application dependent, and it may be desirable in some applications to use this feature.

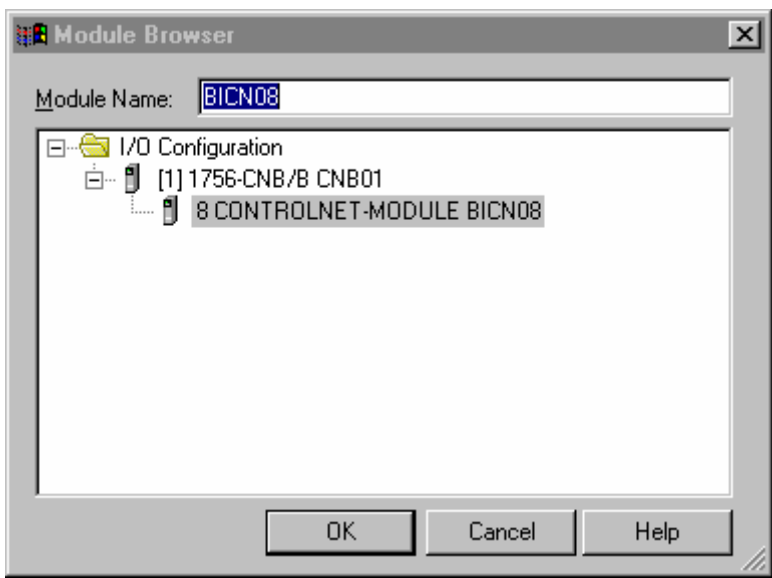
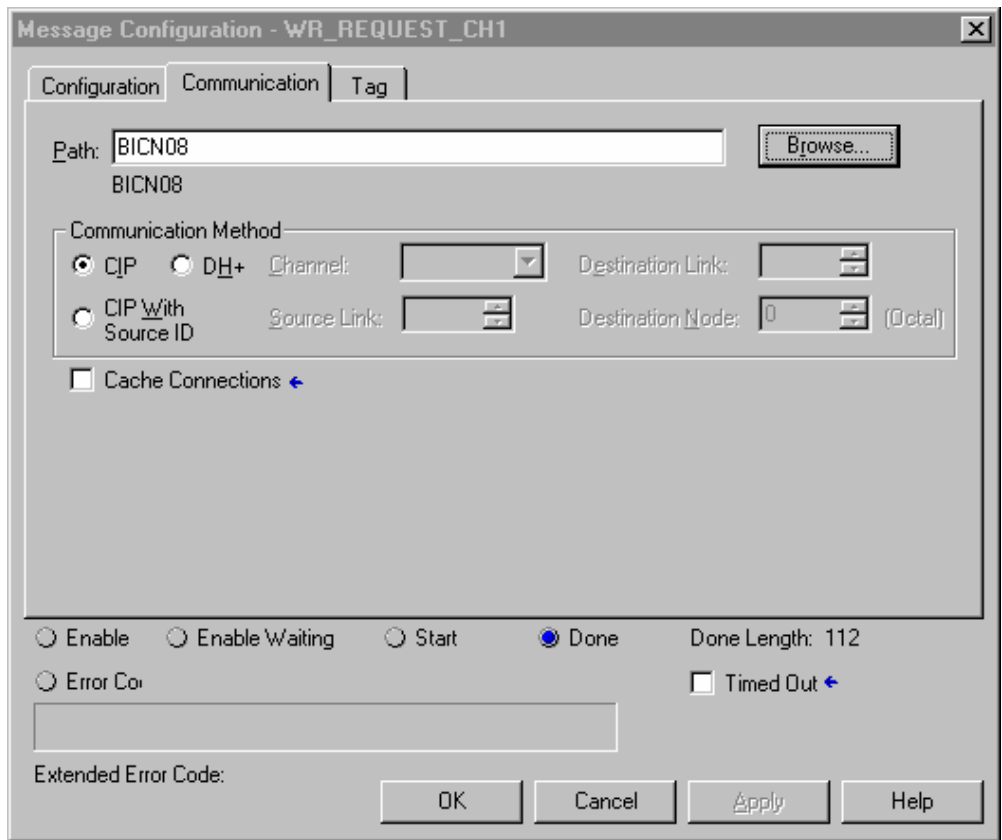

Block Write Program Example, Con't

TAG:

The Name parameter will point to the Message instruction TAG that was created to communicate with the BICN.

The screenshot shows a dialog box titled "Message Configuration - WR_REQUEST_CH1". It has three tabs: "Configuration", "Communication*", and "Tag". The "Tag" tab is selected. The dialog contains the following fields and controls:

- Name:** WR_REQUEST_CH1
- Description:** Message instruction to request a wi
- Tag Type:** Base
- Data Type:** MESSAGE
- Scope:** Manual
- Style:** (empty dropdown)
- Produce this tag for up to 0 consumers
- Radio buttons: Enable, Enable Waiting, Start, Done
- Done Length: 112
- Error Co
- Timed Out
- Extended Error Code: (empty text box)
- Buttons: OK, Cancel, Apply, Help

Block Write Program Example, Con't

Example Logic

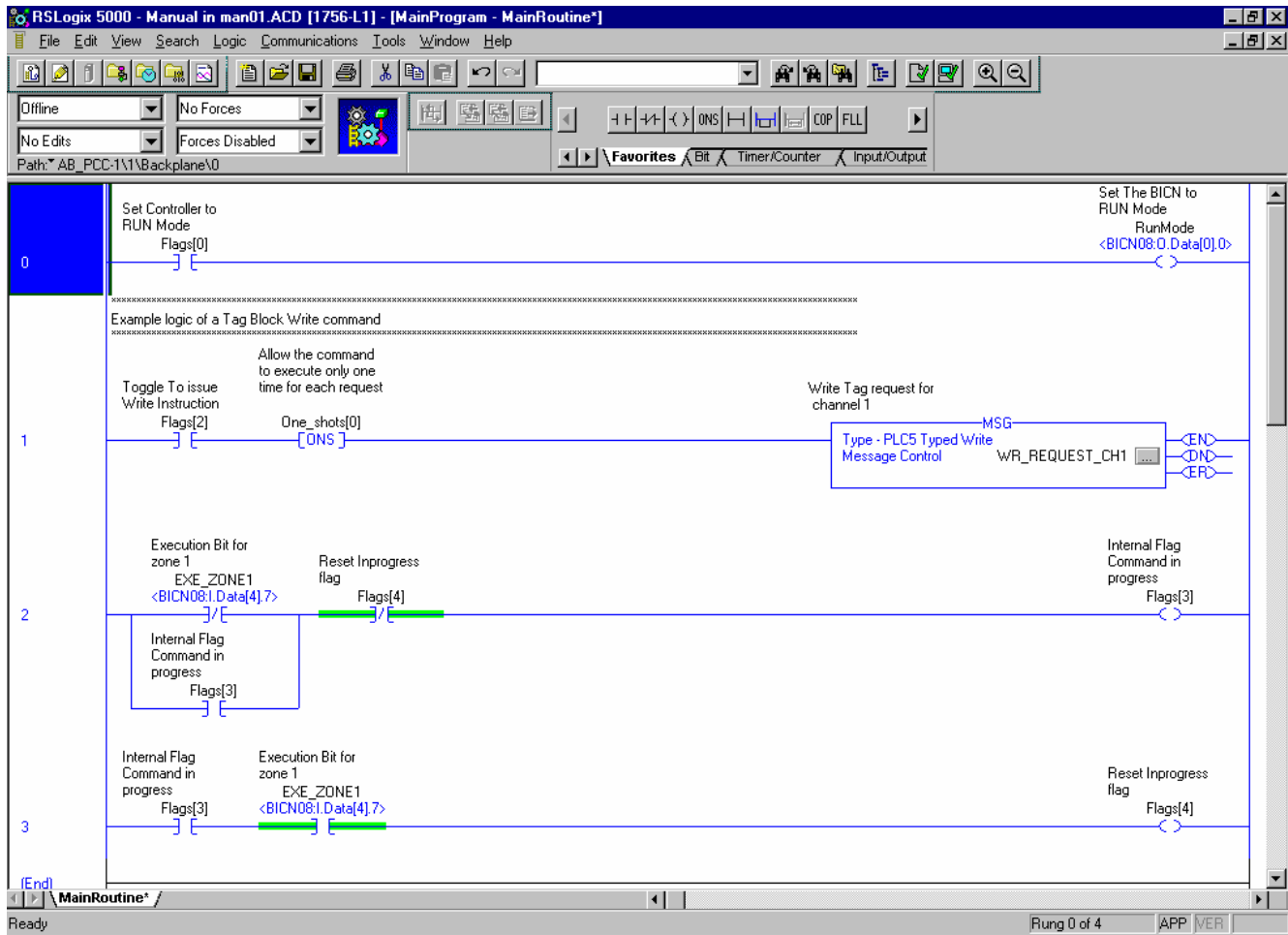

Example Ladder Logic

The following example outlines the steps involved when sending a TAG Block Write request to a BICN module.

Rung 0:

Place the BICN module into run mode by setting Bit 0 of the Module Control Word to 1.

Rung 1:

Send the Typed Write Message instruction to the Command Buffer 1 located at the Destination Element N7:128.

Rung 2:

Monitor the Execution Bit (bit 7) of the Operational Status Result word BICN08:I.Data[4]. This word is associated with Command Buffer 1. The logic is looking for the command execution bit to transition low indicating that the BICN module received the command and an internal holding contact is set true to track the completion of the command.

Rung 3:

Monitor the completion of the command by looking for the execution bit to transition from low back to high, which signals the completion of the command. It is not necessary to read the Results Buffer after the Write operation has completed.

Block Read Program Example

Message Configuration - RD_RESULT_CH1

Configuration | Communication | Tag

Message Type: PLC5 Typed Read

Source Element: N7:1280

Number Of Elements: 130

Destination Tag: CH1_RESULT_BUF New Tag...

Enable Enable Waiting Start Done Done Length: 130

Error Code: Timed Out

Extended Error Code:

OK Cancel Apply Help

Block Read Program Example, Con't

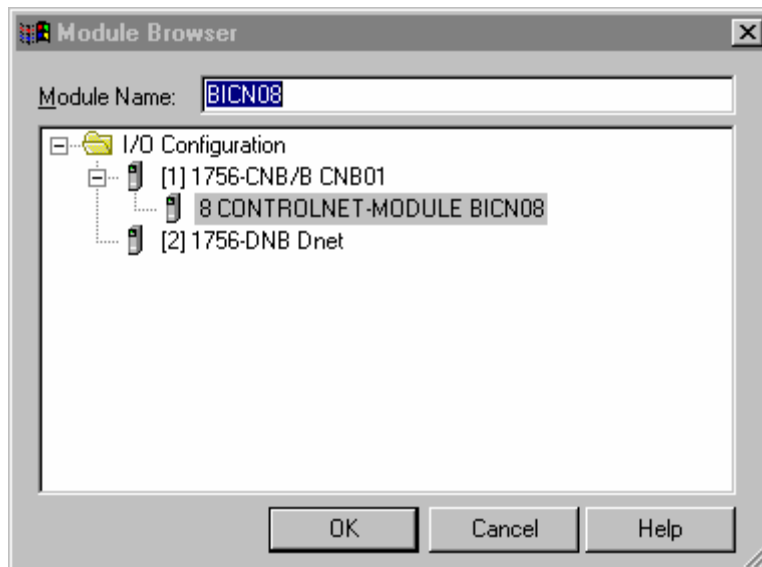
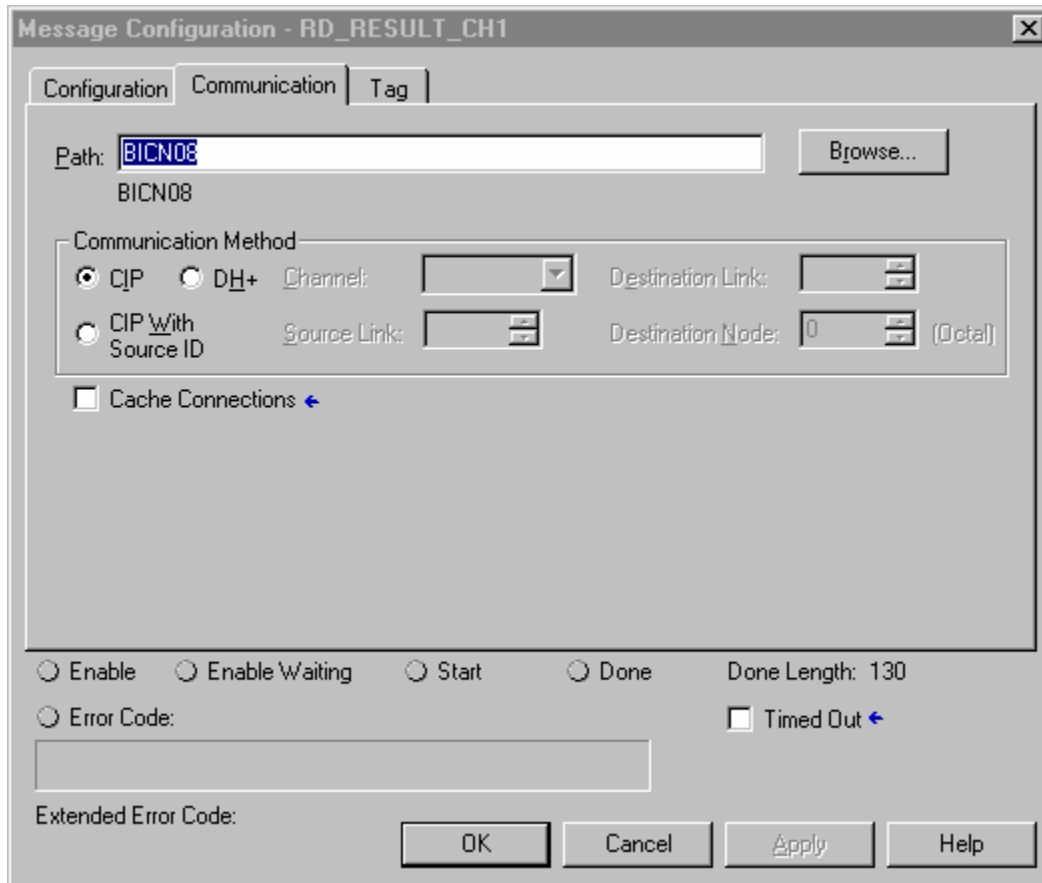

Block Read Program Example, Con't

Message Configuration - RD_RESULT_CH1

Configuration Communication* Tag

Name: RD_RESULT_CH1

Description: Read the results buffer for channel

Tag Type: Base

Data Type: MESSAGE

Scope: Manual

Style: [dropdown]

Produce this tag for up to 0 consumers

Enable Enable Waiting Start Done Done Length: 130

Error Co Timed Out

Extended Error Code:

OK Cancel Apply Help

Block Read Program Example, Con't

Example Logic

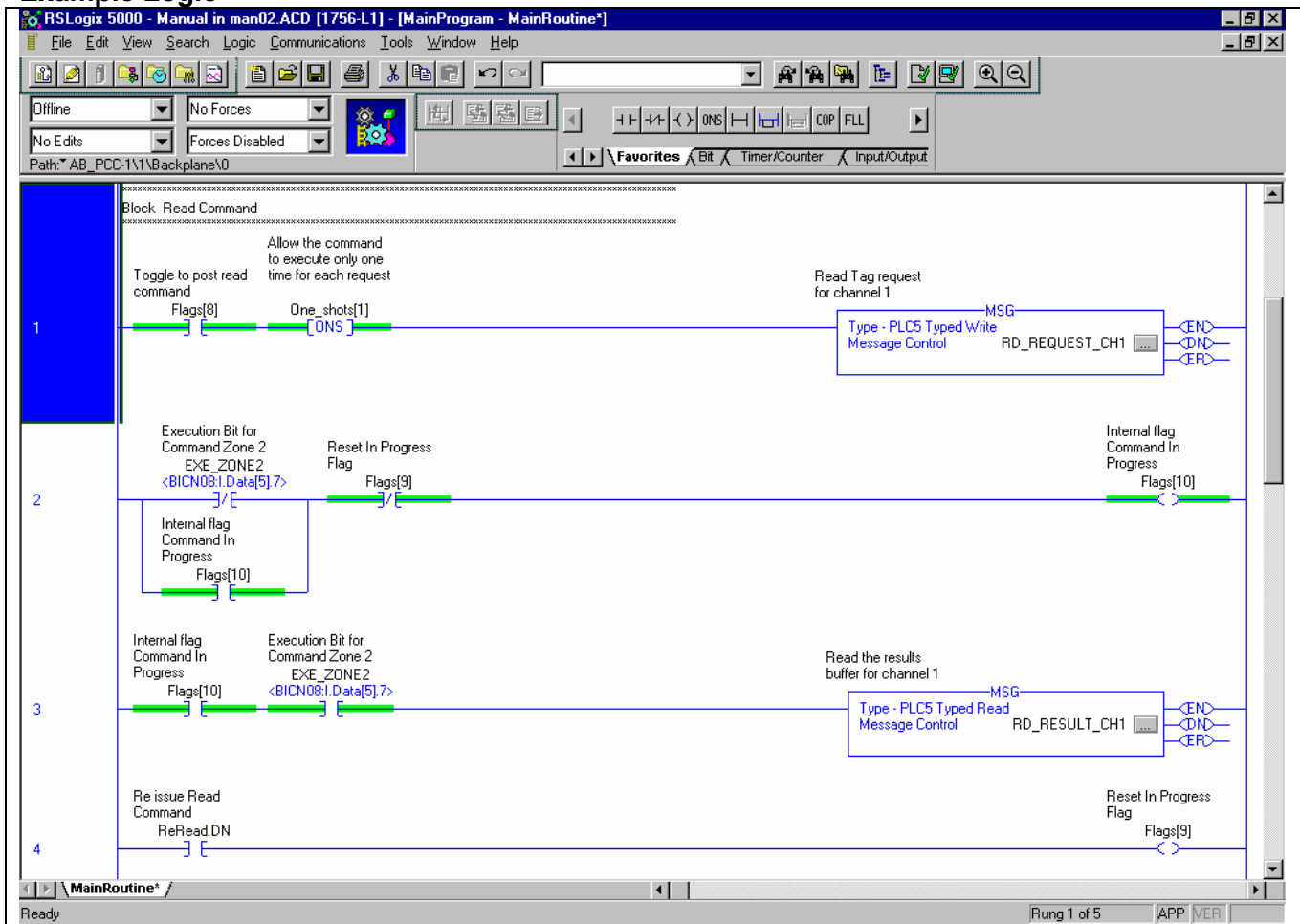

The first step in the setting up of the Block Read command request is identical to the Block Write request. As a matter of review a PLC 5 Typed Write Message instruction is created whose source TAG will point to the integer array where the Block Read command is formatted. The Destination Element will point to a command buffer that will receive and process the command. The command will be issued and the Operational Status Word associated with the command buffer will be monitored until the operation has completed. Once the command has completed the user must retrieve the data from the results buffer using the PLC5 Typed Read Message. It is very important to remember that the returned data is only valid AFTER the Message command's Done bit is TRUE. The following screen captures outline the setup of the PLC5 Typed Read Command.

Rung 1: A set of application related events are normally used to issue the PLC5 Typed Write message (operators push button, pallet in position switch and / or TAG Present indication are some examples). The Message instruction is conditioned with a one-shot to eliminate a continuous stream of requests.

Rung 2: Once the command is issued the ladder logic examines the Execution Bit of the Operational Status Result word related to the Command Buffer. For this example Command Buffer N7:256 is used therefore the Operational Status Result Word is: BICN08:I.Data[5]. When the Execution bit transitions low an internal holding contact is set to record this event.

Rung 3: This rung will test for the Execution bit to return high again. This logic is conditioned with the holding contact from rung 2, which allows it to capture the positive transition that is related to this command execution cycle. When both conditions are True a PLC 5 Typed Read message is issued to Read the Results Buffer at location N7:1280. This data is returned to the Destination TAG that was defined when the message instruction was created. It is important remember that the data transfer between the BICN and the CPU is complete AFTER the Message instructions Done bit is TRUE.

Block Write Program Example (WITH PLC5)

The following screen captures demonstrate how a Message instruction must be configured to send a command request to the BICN'S Command Buffer memory.

Message Configuration:

The Message Type to select is PLC5 Typed Write. The Data Table Address must point to an integer array where the command parameters and data are organized. The Size in Elements parameter is the total number of words that will be transmitted to the BICN. This is determined by adding the 6 bytes, which make up the instruction, to the total number of bytes to be written to the TAG, then dividing by 2 to arrive at the total number of words. If this parameter is too small, only the values received in the message will be utilized and all missing data will be indeterminate. The Port Number is the PLC5's ControlNet channel 2. The Data Table Address must point to 1 of the 8 Command Buffers in the BICN'S memory that is not currently being used. MultiHop is by default set to NO. The ControlNet path is the Node ID of the BICN unit that you are sending the command to.

MSG - MG14:0 : (1 Elements)

General

This PLC-5

Communication Command:

Data Table Address:

Size in Elements:

Port Number:

Target Device

Data Table Address:

MultiHop:

ControlNet Path:

Control Bits

Ignore if timed out (TO):

To be retried (NR):

Awaiting Execution (EW):

Continuous Run (CO):

Error (ER):

Message done (DN):

Message Transmitting (ST):

Message Enabled (EN):

Error

Error Code(Hex):

Error Description

No errors

Block Write Program Example Con't

Example Logic

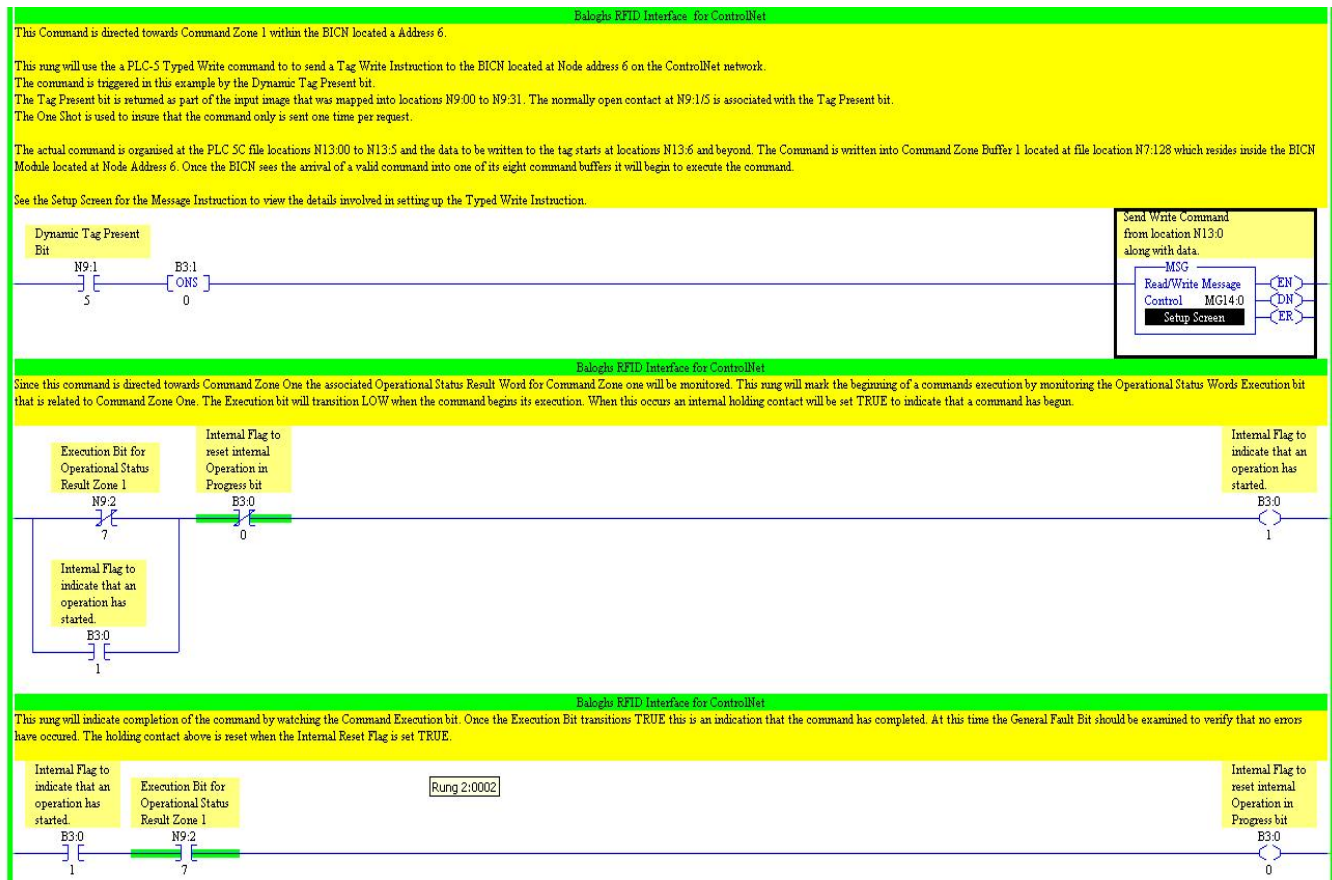

Example Ladder Logic

The following example outlines the steps involved when sending a TAG Block Write request to a BICN module.

Rung 0:

Send the Typed Write Message instruction to the Command Buffer 1 located at the Destination Element N7:128.

Rung 1:

Monitor the Execution Bit (bit 7) of the Operational Status Result word N9:2/7. This word is associated with Command Buffer 1. The logic is looking for the command execution bit to transition low indicating that the BICN module received the command and an internal holding contact is set true to track the completion of the command.

Rung 2:

Monitor the completion of the command by looking for the execution bit to transition from low back to high, which signals the completion of the command. It is not necessary to read the Results Buffer after the Write operation has completed.

Block Read Program Example

Write Message instruction is sent down to the BICN to start the read.

MSG - MG14:1 : (1 Elements)

General

This PLC-5

Communication Command:

Data Table Address:

Size in Elements:

Port Number:

Control Bits

Ignore if timed out (TO):

To be retried (NR):

Awaiting Execution (EW):

Continuous Run (CO):

Error (ER):

Message done (DN):

Message Transmitting (ST):

Message Enabled (EN):

Target Device

Data Table Address:

MultiHop:

ControlNet Path:

Error

Error Code(Hex):

Error Description

No errors

Block Read Program Example, Con't

A read command is sent down to the BICN to read the data that has been read from the TAG.

The screenshot shows a software window titled "MSG - MG14:2 : (1 Elements)". The window contains a "General" tab with the following configuration fields:

- This PLC-5**
 - Communication Command:
 - Data Table Address:
 - Size in Elements:
 - Port Number:
- Target Device**
 - Data Table Address:
 - MultiHop:
 - ControlNet Path:
- Control Bits**
 - Ignore if timed out (TO):
 - To be retried (NR):
 - Awaiting Execution (EW):
 - Continuous Run (CO):
 - Error (ER):
 - Message done (DN):
 - Message Transmitting (ST):
 - Message Enabled (EN):
- Error**
 - Error Code(Hex):
- Error Description**
 - No errors

Block Read Program Example, Con't

Example Logic

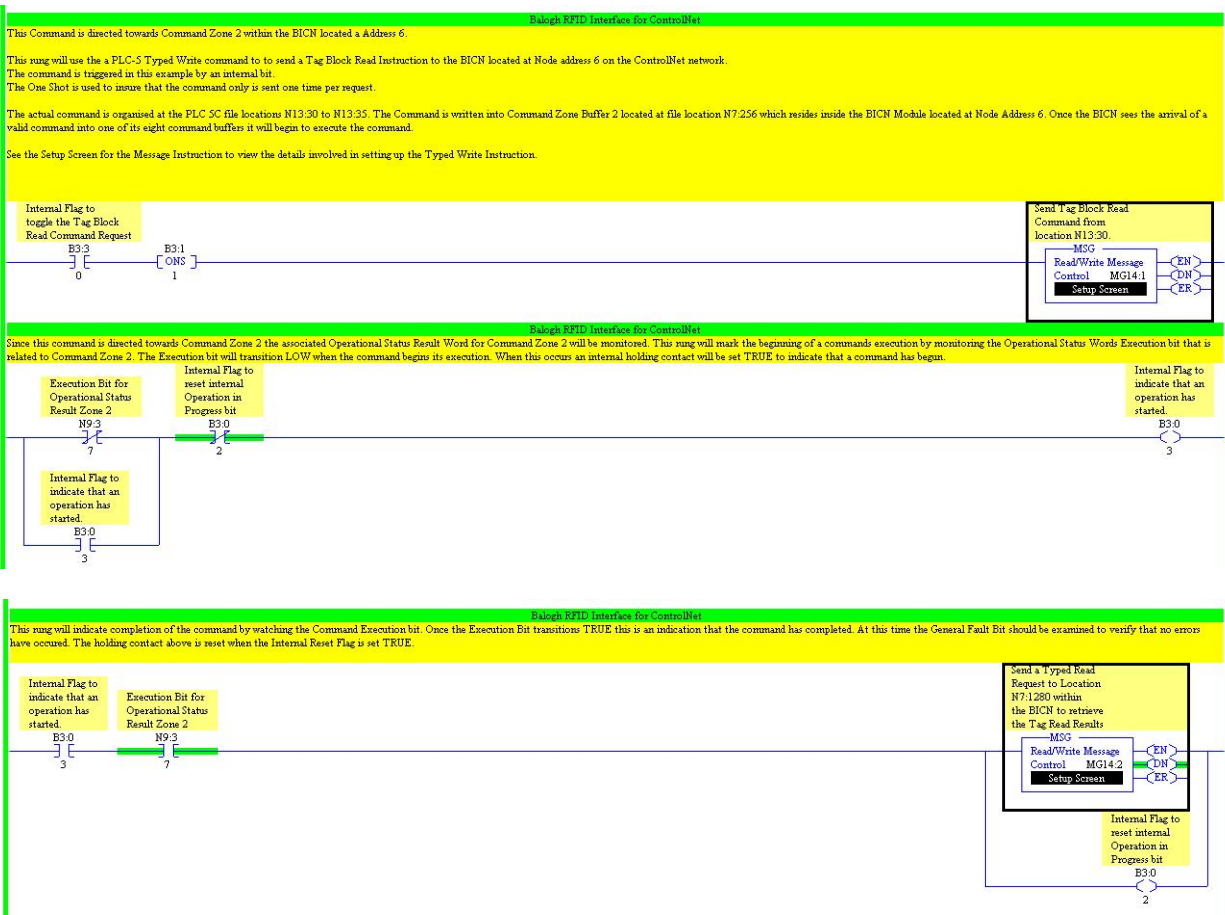

The first step in the setting up of the Block Read command request is identical to the Block Write request. As a matter of review a PLC 5 Typed Write Message instruction is created whose source TAG will point to the integer array where the Block Read command is formatted. The Data Table Address will point to a command buffer that will receive and process the command. The command will be issued and the Operational Status Word associated with the command buffer will be monitored until the operation has completed. Once the command has completed the user must retrieve the data from the results buffer using the PLC5 Typed Read Message. It is very important to remember that the returned data is only valid AFTER the Message command's Done bit is TRUE. The following screen captures outline the setup of the PLC5 Typed Read Command.

Rung 1: A set of application related events are normally used to issue the PLC5 Typed Write message (operators push button, pallet in position switch and / or TAG Present indication are some examples). The Message instruction is conditioned with a one-shot to eliminate a continuous stream of requests.

Rung 2: Once the command is issued the ladder logic examines the Execution Bit of the Operational Status Result word related to the Command Buffer. For this example Command Buffer N7:256 is used therefore the Operational Status Result Word is: N9:3/7. When the Execution bit transitions low an internal holding contact is set to record this event.

Rung 3: This rung will test for the Execution bit to return high again. This logic is conditioned with the holding contact from rung 2, which allows it to capture the positive transition that is related to this command execution cycle. When both conditions are True a PLC 5 Typed Read message is issued to Read the Results Buffer at location N7:1280. This data is returned to the Destination TAG that was defined when the message instruction was created. It is important remember that the data transfer between the BICN and the CPU is complete AFTER the Message instructions Done bit is TRUE

Troubleshooting Tips

Problem: If you are getting a 0F hex error (TAG Dialogue Fault)

Solution: Make sure you don't have your timeout set to too small of a time for the operation to complete. If the command takes longer to complete than your timeout the channel will error out. Also, if the TAG is moving through the zone and leaves the zone before the command completes will cause the error.

Problem: If you are getting a message instruction error of 0001 and an extended code of 0301 "NO BUFFER MEMORY"

Solution: You are sending out too many message instructions at one time for the CPU to handle. Check your logic to re sequence your message instructions.

BICN Error Codes

Specific Error Description	
Fault Code	Meaning
01 Hex	Invalid Data Length Fault
05 Hex	Internal Channel Communication Fault
0B Hex	TAG Address Fault
0C Hex	Transceiver Fault
0E Hex	TAG Memory Fault
0F Hex	TAG Dialogue Fault

TAG Addressing:

TAG Type		Address in bytes (Decimal)
OF/OFR	7 byte Read Only	0 to 6
OL/OLR	2 byte Read Only Extended Range	0 to 1
OMA	64 byte Read Write	2048 to 2111
OMA	2K byte Read Write	0 to 2047
OMA	8K byte Read Write	0 to 8180
OMX	8K byte Read Write	0 to 8180
OMX	32K byte Read Write	0 to 32767
OIR	32K byte Infra-Red Read Write	0 to 32767
OIR	64K byte Infra-Red Read Write	0 to 65535
GIE	512 byte Read Write	0 to 511
GIE	2K byte Read Write	0 to 2047
GIE	8K byte Read Write	0 to 8180
OP	64 byte Read Write	0 to 63 (Read) 12 to 75 (Write)
OP	96 byte Read Write	0 to 95 (Read) 12 to 107 (Write)

BALOGH



ControlNet[®] Control Board BICN

Identification - Coding

Reference: BICN

A=	OMA	64, 2K, or 8K bytes Read/Write TAG
P=	OP	64 byte & 96 byte Read/Write TAG
X=	OMX	High Speed 8K & 32K byte Read/Write TAG
E=	GIE	512, 2K, 8K byte Read/Write TAG
I=	OIR	64K byte Read/Write TAG
F=	OF or OFR	7 bytes Read-Only TAG
L=	OL or OLR	2 byte Read-Only Extended Range TAG

Characteristics

- The BALOGH BICN meets the needs required for today's network flexibility. It is also compatible with existing network devices such as I/O, push button, motion controls, motor starters, photo cells, limit switches, etc.
- Multi-Drop capability: Allows a connection scheme of multiple BICN interface units on a ControlNet[®] network. Each BICN has dual channel capability. Two Transceivers can be connected to each BICN. Each functions independently and simultaneously.
- Small footprint provides ease of mounting (191mm x 130mm x 69mm). With an IP-12 rated metallic enclosure and quick connect wiring, it provides field mounting, durability, and reduces wiring costs.
- Automatic self-test upon power-up.
- Node Addressing from 0-99.
- LED indication for network and Module Status, TAG presence, and Transceiver error:

The BICN is equipped with 10 status LEDs that are externally visible.

2 Bicolor LED indicating the health of network cable connection A and B

3 LEDs per Transceiver channel:

- TAG Present (Green)
- Operation In Progress (Green)
- Transceiver/command execution fault (Red)

1 Green LED indication of 24 VDC power

1 Bicolor LED indicating the state of the user serial port

Revised: November 07, 2002



Characteristics	Symbol	Unit	BICN
Supply Power ($\pm 1\%$)	Ucc	V	24 VDc
Consumed Current	Io	mA	350mA
Ambient Temperature	T	$^{\circ}\text{C}$	$^{\circ}\text{C}$ to 70°C
Protection Degree	IP	/	IP 12
Weight	M	G	815

Dimensions

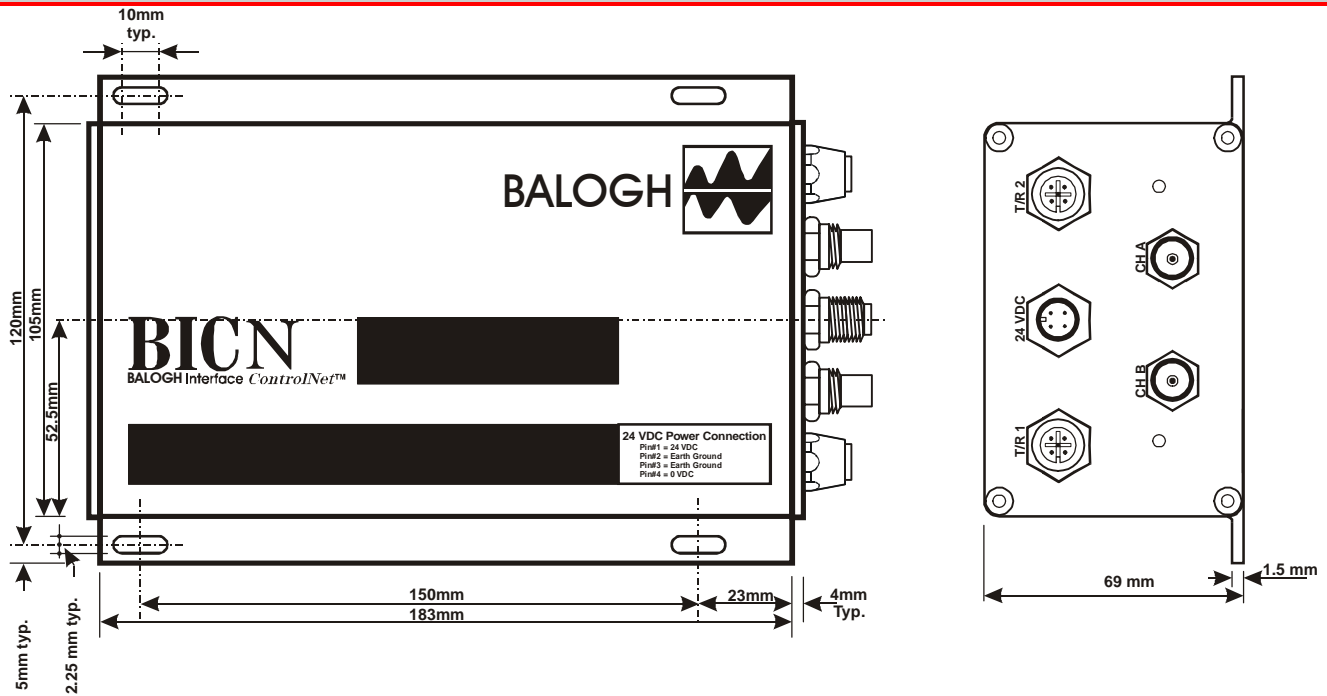

Connections

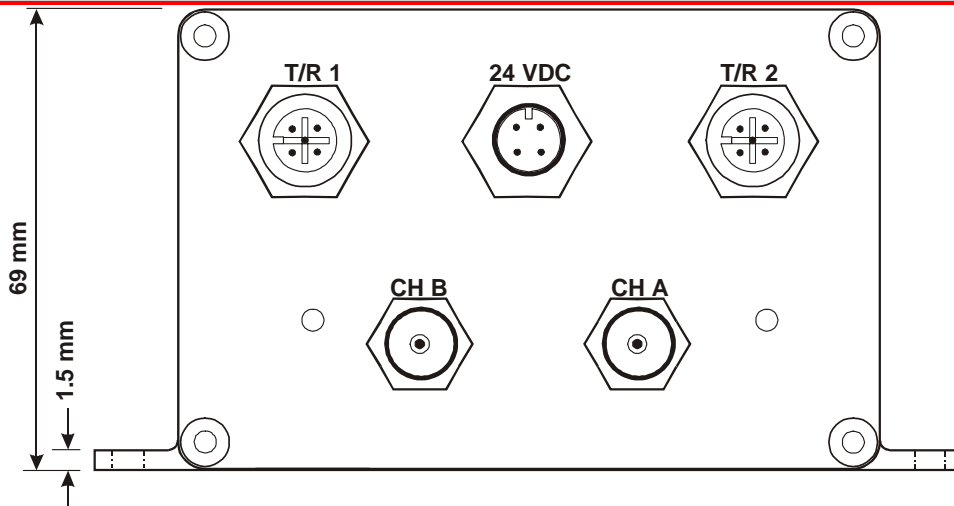

BICN EDS File

[File]

DescText = "BICN ControlNet - Adapter EDS";
CreateDate = 11-26-2003;
CreateTime = 12:26:00;
ModDate = 12-04-2003;
ModTime = 11:30:03;
Revision = 2.0;

[Device]

VendCode = 133;
VendName = "BALOGH";
ProdType = 1;
ProdTypeStr = "Balogh ControlNet - Adapter";
ProdCode = 1;
MajRev = 1;
MinRev = 4;
ProdName = "BICN Adapter (1.4.R5)";
Catalog = "BICN 100S";
Icon = "Balogh.ico";

[Device Classification]

Class1 = 1_RSNetWorx_Adapter;
Class2 = ControlNet;

[Port]

Port2 = ControlNet_Redundant,
"Port A",
"20 F0 24 01",2;

[Params]

\$ The Params entries consist of the following:
\$ Reserved (0),
\$ Link Path Size,
\$ Link Path,
\$ Parameter Descriptor,
\$ Data Type Identifier,
\$ Data Size,
\$ Parameter Name,
\$ Units String,
\$ Help String,
\$ Minimum Value,
\$ Maximum Value,
\$ Default Value,
\$ Scaling Multiplier,
\$ Scaling Divider,
\$ Scaling Base,
\$ Scaling Offset,
\$ Multiplier Link,
\$ Divisor Link,
\$ Base Link,
\$ Other Link,
\$ Decimal Precision,

BICN EDS File continued

```
Param2 = 0, , 0x0000, 2, 2, "Output Size", "", "", 1, 64, 64, 0, 0, 0, 0, 0, 0, 0, 0;  
Param3 = 0, , 0x0000, 2, 2, "Input Size", "", "", 8, 68, 68, 0, 0, 0, 0, 0, 0, 0, 0;
```

[Connection Manager]

\$ The following describes a limited use read/write connection.

```
Connection1 =  
  0x04010002,          $ class 1, cyclic, exclusive owner  
  0x44240405,          $ O=>T scheduled, p2p or multicast, run/idle header  
                        $ T=>O scheduled, p2p or multicast, 64-bit status header  
  , Param2, ,          $ O=>T RPI, size, format  
  , Param3, ,          $ T=>O RPI, size, format  
  , ,                  $ config part 1 (unused)  
  , ,                  $ config part 2 (unused)  
  "Exclusive Owner", "", $ connection name string, help string  
  "20 04 24 01 2C 01 2C 02"; $ Path to target object  
1_PLC5C_RTD_Format1 = 1_PLC5C_1794_Discrete_RTD_Format;
```