

# **ASSEMBLY MANUAL**

**Industrial Range Products  
“OC”, “OLR”, “OF”, “OMA”, “GIE, “OMX” Series**

**BALOGH**

Notes are to call attention to information that is significant to the understanding and operation of equipment.

The BALOGH Assembly manual is based on information available at the time of its publication. We have attempted to provide accurate and up-to-date information. This document does not purport to cover all details or variations in hardware or software; nor does it provide for every possible combination of products. Some features described herein may not be available on all like products. BALOGH assumes no obligation to notify holders of this document of any subsequent changes.

BALOGH makes no representation or warranty, expressed, implied or statutory with respect to, and assumes no responsibility for the accuracy, completeness, or usefulness of the information contained in this manual. No warranties of merchantability or fitness for purpose shall apply.

This device complies with part 15 of the FCC Rules. Operation is subject to the following two conditions: (1) This device may not cause harmful interference, and (2) this device must accept any interference received, including interference that may cause undesired operation.

© Copyright BALOGH 2009

# MANUAL REVISION HISTORY

<u>Revision Description</u>	<u>Latest Revision Date</u>	<u>Revision Number</u>	<u>Approval Date</u>
Change Address	04/14/10	3	04/14/10

# Table of Contents

<b>1</b>	<b>Overview.....</b>	<b>page: 1</b>
1.1	Advantages of the BALOGH RFID System.....	1
1.2	BALOGH RFID System Operation.....	1
1.3	Transceiver Operation.....	2
1.4	Control Board Operation.....	2
1.5	Electronic TAG Operation.....	3
1.5a	Fixed Code TAGS OC series.....	3
1.5b	Fixed Code TAGS OF/OFR/OL series.....	4
1.5c	Read/Write TAGS OMA/OMX/GIE series.....	5
<b>2</b>	<b>Primary Transmission zones.....</b>	<b>5</b>
2.1	Types of Transmission zones.....	5
<b>3</b>	<b>“On-the-fly” Reading or Writing.....</b>	<b>7</b>
3.1	Operating conditions.....	7
3.2	Example.....	8
3.3	Directional arrows.....	8
<b>4</b>	<b>Configuration recommendations.....</b>	<b>9</b>
4.1	Potential Transmission zones.....	9
4.2	Recommended distance between two Transceivers (Der).....	10
4.3	Recommended distance between two TAGS (Det).....	10
4.4	Transceiver mounting guidelines.....	11
4.5	TAG mounting guidelines.....	12
4.6	Special Transceiver configurations.....	14
<b>5</b>	<b>Electrical Connections.....</b>	<b>15</b>
5.1	Power supply.....	15
5.2	Parallel connections.....	15
5.2.1	Input characteristics.....	15
5.2.2	Output characteristics.....	15
5.3.1	RS-232 Serial connection.....	16
5.3.1a	Input characteristics.....	16
5.3.1b	Output characteristics.....	16
5.4	Cable for Transceiver connection.....	17
5.4.1	Transceiver wiring.....	17
5.4.2	Cable applications.....	18-19



# 1 Overview

## 1.1 Advantages of the BALOGH RFID System:

- Absolute data security with no possibility of degraded data entering the system
- Remote, non-contact Reading and Writing
- Reading and/or Writing of stationary TAGS or TAGS "On-the-fly"
- Large angular and lateral axial offsets
- Large Reading and Writing ranges
- Read-Only or Read/Write TAGS
- Data stored in TAG memory is secure for 10 years or more
- Unlimited number of Read/Write operations
- Parallel, serial and multiple field bus interfaces, for flexibility when choosing PLCs, computers, or relays
- Multiplexing of Control Boards
- Simplified wiring
- Unaffected by interference, will Read and Write in intense electromagnetic fields without risking data integrity
- High resistance to severe industrial conditions, such as temperature, water, coolant oil, detergents, paint, metal chips, etc.

## 1.2 BALOGH RFID System Operation:

BALOGH TAGS are PASSIVE, meaning that no power source in the TAG is necessary when exchanging data, other than the energy supplied by the electromagnetic field. BALOGH Radio Frequency Systems identify and control free-moving components, such as pallets on an automated conveyor belt or Automatic Guidance Vehicles. A system typically consists of a TAG, a Transceiver, Control Board and a Control Board Holder. Using the principle of inductive transmission, data can be exchanged without contact whenever the TAG enters the electromagnetic field generated by a Transceiver. Since BALOGH offers Read ranges of up to 0.5 meters, most mechanical clearance and alignment concerns are eliminated. Data transmission between the TAG and Transceiver takes place in serial mode. Since communications depend only upon the proximity of the two devices, the direction of travel of the approaching TAG is of no significance to the Transceiver.

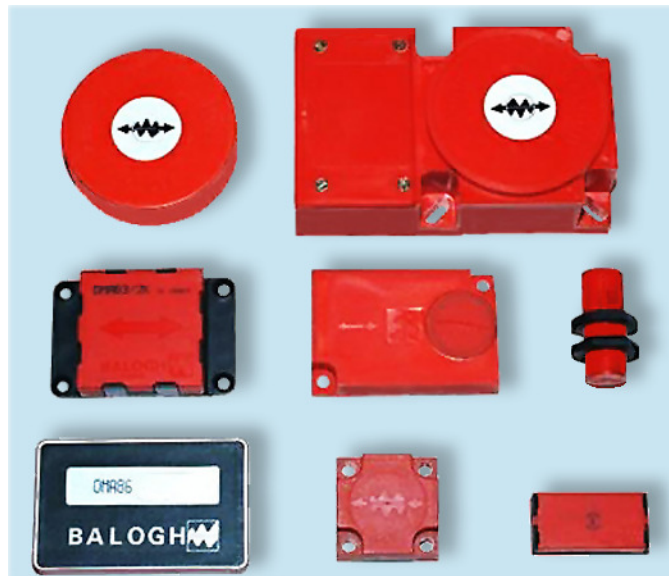

# Transceiver Operation

## 1.3 Transceiver Operation:

A Transceiver is necessary for any identification or coding application. Its function is essential to the system's basic operation because it is the Transceiver that establishes the electromagnetic field that provides the power for the TAG. Aside from energy emission, the Transceiver is also the conduit for data transmission and data reception. In order to perform a Read or Write operation, Transceivers must be wired to a Control Board. They are connected by a serial link requiring 4 conductors (twin shielded pairs). These two components work together to allow the reception from, or transmission to, a TAG in the Transmission zone. Transmission zones vary in size depending on the Transceiver chosen.

## Three factors determine the basis for selecting a Transceiver:

- Model, shape and mounting requirements of the Transceiver.
- Transmission zone dimensions.
- The proximity of the next Transceiver.

## Transmission Zone

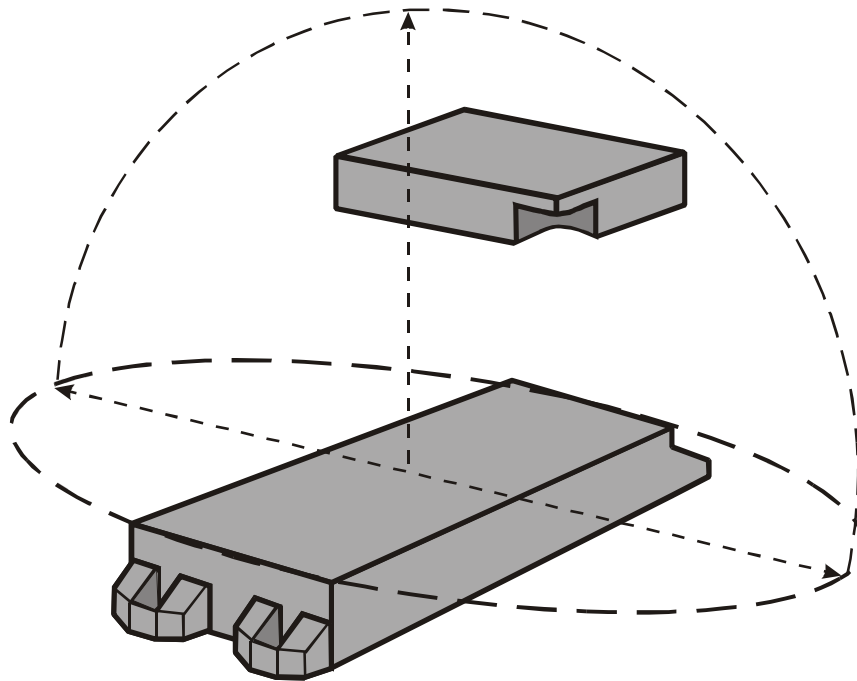

## 1.4 Control Board Operation:

The link between the user's control or logic system (PLC or PC) and the Transceiver/TAG communication is the BALOGH Control Board. Like all components of the BALOGH RFID System, the choice of Control Board will depend upon the application. Whether an application calls for Read-Only or Read/Write, "On-The-fly" or Static Transmission, BALOGH Transceivers, TAGS and Control Boards can be mixed and matched until the combination fits the application.

Answering the following questions will help to determine which Control Board best suits the needs of the application

- Is it a Read/Write or Read-Only application?
- What type of interface is needed? (Serial, Parallel or bus)
- Are you using a field bus network? (DeviceNet<sup>®</sup>, G.E. Genius<sup>®</sup>, InterBus-S<sup>®</sup>, etc.)
- What kind of Controller? (PLC, PC, etc.)
- Does the application need stand-alone control with independent I/O?

BALOGH has a large selection of Control Boards and interfaces to meet your needs.

#### **BALOGH BIDN, Control Board for Allen-Bradley DeviceNet<sup>®</sup>:**



### **1.5 Electronic TAG Operation:**

Two categories of TAGS are available: Read-Only and Read/Write. Each TAG is available in a variety of shapes and sizes, with varying memory capabilities. All BALOGH TAGS are PASSIVE and receive power from the BALOGH Transceiver for communications. The following describes the different categories of TAGS.

#### **1.5a Fixed Code TAGS OC series:**

Also called Read-Only TAGS, these TAGS can carry an eight bit binary code. The OC series Fixed Code TAGS are encoded BY THE USER, providing the following possible combinations: for eight bits, 0-255. To encode the TAG, open the chamber that houses 8 wire straps. By cutting or not cutting the wire straps, a binary value is designated for the TAG. Cutting a strap will signify a binary "0", while leaving it uncut will signify a "1". The least significant bit will be indicated by a dot of paint.



**\*OC-93 TAG shown above with all eight straps connected for a value of 255**

BALOGH 3637 Old US-23 Suite 100 Brighton, MI 48114 - (810) 360-0182- Subject to Modification

# Read Only TAGS

## 1.5b Fixed Code TAGS OF/OFR/OL series:

The OF series 7 byte Read-Only TAGS are available for applications where a larger amount of Fixed Code data needs to be stored (see data sheets for dimensions). The price of the OF series TAGS makes applications which call for a large number of TAGS very economical. These TAGS are coded at the factory to user specifications with 256 combinations available. The OFR series 7 byte Read-Only TAG is a user re-programmable TAG using the CPF-88 Handheld and programming cable. This TAG operates the same as the OF TAG, with the exception of the Read-Only data on the TAG, which can be changed when the programming cable is connected to a port on the TAG and the CPA-88 Handheld is used to change the data. The OFR TAG is available only in 56, 85, & 93 TAG series. The OL series TAG is a 2 byte Read-Only TAG available in the 85 series case. The OL series was specifically designed to provide extended read ranges of up to 0.5 meters. When ordering OF or OL TAGS, a coding sheet must accompany your purchase order to manufacture and code the TAGS. Below is an example of the OF TAG coding sheet:

### TAG Coding Sheet for BALOGH "OF" Read Only TAGS

TAG Coding Format (Check Box Below)  
Decimal:  Hex:   
*If TAGS are not to be coded in sequential order then you must have one coding sheet per TAG.*

---

**Tags to be programmed in Sequential Order:**

Total number of TAGS in order:  Coding # for first TAG:  Coding # for last TAG:

In the boxes below fill in the the number you want programmed in each byte and select either Decimal or Hexidecimal

FIRST TAG (in sequence) CODING:

Byte 0	Byte 1	Byte 2	Byte 3	Byte 4	Byte 5	Byte 6
<input type="text"/>	<input type="text"/>	<input type="text"/>	<input type="text"/>	<input type="text"/>	<input type="text"/>	<input type="text"/>

LAST TAG (in sequence) CODING:

Byte 0	Byte 1	Byte 2	Byte 3	Byte 4	Byte 5	Byte 6
<input type="text"/>	<input type="text"/>	<input type="text"/>	<input type="text"/>	<input type="text"/>	<input type="text"/>	<input type="text"/>

---

**Tags to be programmed Individually:**

In the boxes below fill in the the number you want programmed in each byte and select either Decimal or Hexidecimal

Byte 0	Byte 1	Byte 2	Byte 3	Byte 4	Byte 5	Byte 6
<input type="text"/>	<input type="text"/>	<input type="text"/>	<input type="text"/>	<input type="text"/>	<input type="text"/>	<input type="text"/>

*Non-Sequential TAG coding must have one coding sheet per TAG.*

Purchase Order Number: \_\_\_\_\_ TAG Catalog Number on Order: \_\_\_\_\_

Signature: \_\_\_\_\_ Date: \_\_\_\_\_  
*Coding sheet must be signed in order to manufacture and code tags.*

**NOTE: Once the Read Only TAGS are programmed during manufacturing the coding can not be changed. By signing this coding sheet you affirm that the above tag coding is correct and assume all responsibility for tags coded to this specification. Tags are Not Returnable, and Non-Refundable.**

Please fax this coding sheet along with the Purchase Order to BALOGH at: (248) 486-0404

If you have any questions please give BALOGH a call: (800) 252-RFID (7343)



If you have questions on filling out the coding sheet or need a TAG coding sheet faxed to you, call BALOGH @ 800-252-RFID

BALOGH 3637 Old US-23 Suite 100 Brighton, MI 48114 - (810) 360-0182- Subject to Modification



# Read/Write TAGS

## 1.5c Read/Write TAGS OMA/OMX/GIE series:

The OMA TAG series is available with 64 bytes, 2K bytes or 8K bytes of memory. The OMX series is available with 8K bytes or 32K bytes of memory. The GIE series is available with 512, 2K or 8K bytes of memory. Not all memory configurations are available in all OMA TAG Styles. Data is stored in an OMA, OMX and GIE TAGS using Ferro Electric memory. This allows these TAGS to have unlimited Reads and  $10^{10}$  Write capability. When calculating “On-the-fly” operations for the data transmission speed between OMA, OMX or GIE TAGS and a BALOGH Transceiver, use the following:

OMA TAGS: 10ms per byte + 50 ms per instruction  
OMX TAGS: 0.4ms per byte read and 0.6ms per byte written, zero overhead for instructions  
GIE TAGS: 5ms per byte, zero overhead for instructions

Read/Write TAG data is easily accessed and updated, providing the user with immediate information (Real Time). Criteria used for selecting a TAG are:

- Model, shape and mounting configurations of the TAG
- Read/Write distance (TAG and Transceiver dependent)
- Memory capacity

## ERO-85/QC Transceiver & OMA-931 TAG:

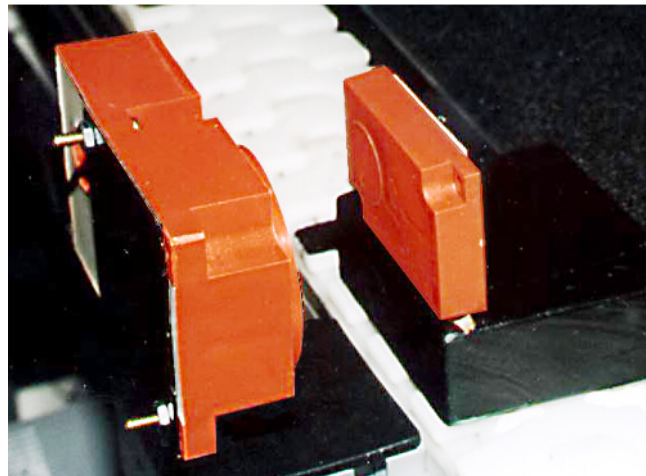

## 2 Primary Transmission zones:

The Transceiver establishes a semi-spherical electromagnetic field. The orientation of the TAG to the Transceiver is shown with directional arrows on both the Transceiver and TAG (See section 3.3). It is important to align these arrows so that the optimal Reading and Writing range can be achieved. See section 3.3 for details. Maximum Range is defined as H and is used to define Sr: Sr is the maximum distance between a TAG and a Transceiver. This value corresponds to range H, modified by a coefficient:  
 $Sr = H * 0.4$

### 2.1 Types of Transmission zones:

The semi-spherical zone in which a stationary TAG can be Read or Written to, with complete security, is the Static Transmission zone. The values for the following variables are found on each individual product data sheet.

- H: Maximum Range of Transmission zone
- Sr: Typical height of Transmission zone at Sr
- L: Typical length of Transmission zone at Sr
- I: Typical width of Transmission zone at Sr

When referring to the data sheets for information concerning the Static Transmission zone, the variables  $H$ ,  $S_r$ ,  $L$ , and  $I$  are shown as typical values with tolerances of  $\pm 20\%$ . The formula for  $S_r$  gives the maximum and minimum values for the Transmission Zone, taking into account dispersion due to ambient temperature, production activities, and mechanical clearances (see fig. 2.A).

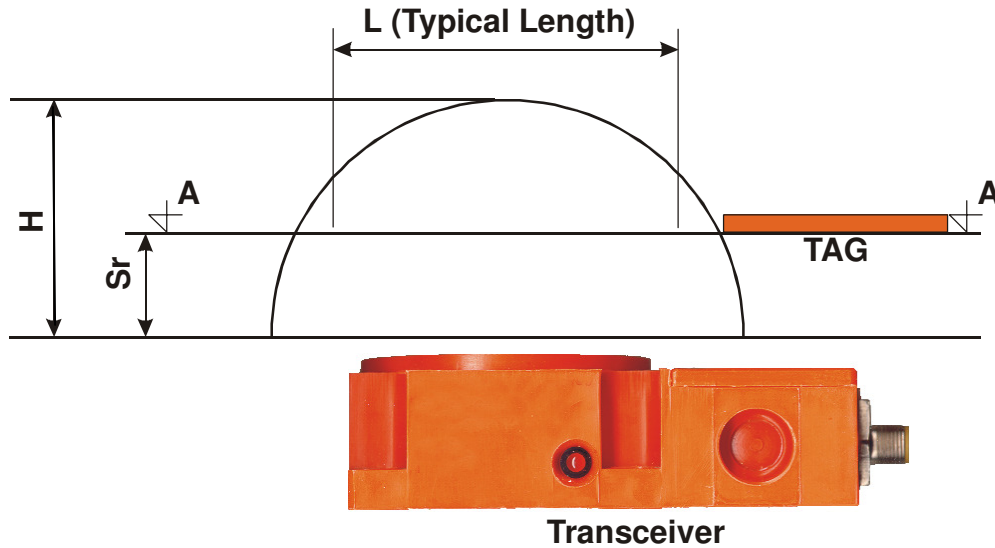

**Figure 2.A Transceiver Zone Cross Section:**

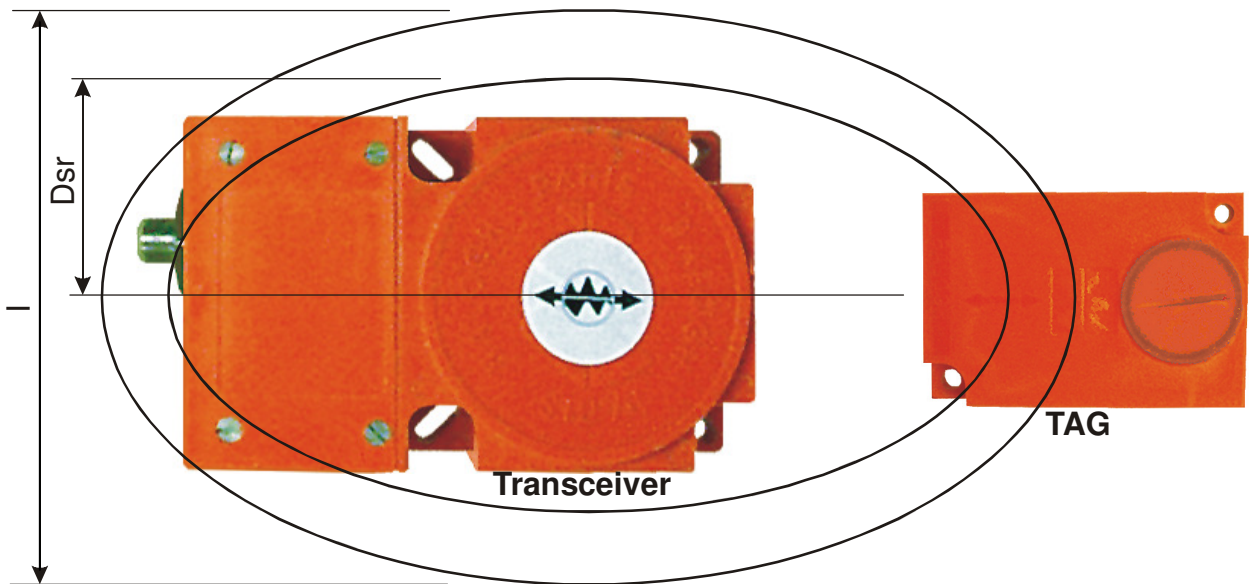

**Figure 2.B Dynamic Transceiver Transmission Zone:**

The Dynamic Transmission zone is a window relative to the Static Transmission zone where it is possible to Read or Write to a TAG in motion. Data is transmitted with complete security, even when severe industrial conditions prevail and metal is present. Whether Reading and Writing blocks of data or a single bit, data integrity remains intact.

For Reading or Writing “On-the-fly”, the following conditions apply: (please see data sheets for product specifications)

**LSr:** Minimum length of Dynamic Transmission zone for a maximal lateral and angular offset.

**DSr:** Maximum lateral offset of the Dynamic Transmission zone (fig. 2.C).

— Maximum angular offset of the Dynamic Transmission zone (fig. 2.D).

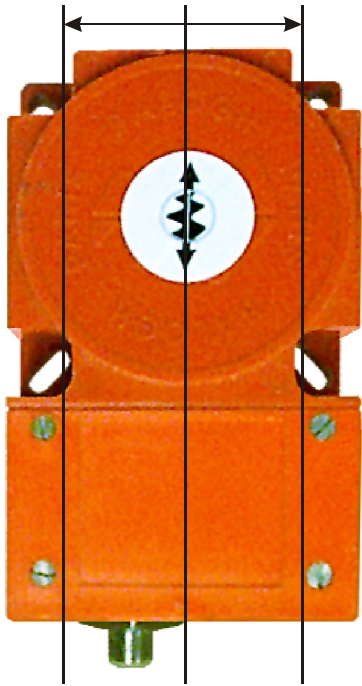

**Figure 2.C**

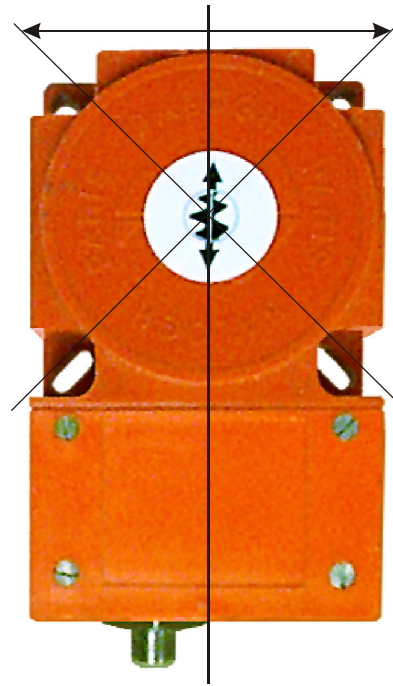

**Figure 2.D**

**Note:**

The values **Sr** and **L Sr** should be used as the basis for calculating the rates of travel and/or the number of bytes that can be Written or Read “On-the-fly” (figs. 2.A and 2.B). These values, based on lab tests and field industrial conditions, already take into account problems that may occur under certain conditions, such as:

- Mechanical clearances, including angular and lateral offsets
- Metallic environments
- Electrical environments
- Abusive thermal and physical environments (water, solvents, coolant oil, etc.)

### 3 “On-the-fly” Reading or Writing:

#### 3.1 Operating conditions:

In order to Read or Write “On-the-fly”, the following variables must be known:

- TAG rate of travel (**V TAG**)
- Distance between the TAG and the Transceiver (**Sr**)
- Length of the Dynamic Transmission zone which determines the rate of travel or the time of TAG presence in the window (**L Sr**)
- Read or Write time per byte (**TS**)
- Number of bytes to be Read or Written (**n**)

Calculation for Reading, Writing “On-the-fly”:

Convert **LSr** from millimeters to meters by dividing by 1000.

$$\mathbf{Td} \text{ (Time in Zone, in seconds)} = \frac{\mathbf{L Sr} \text{ (in meters)}}{\mathbf{V TAG} \text{ (in meters per second)}}$$

Convert **Td** in seconds to milliseconds by multiplying by 1000.

$$\mathbf{n} \text{ (Number of bytes to Read/Write)} = \frac{\mathbf{Td} \text{ (in milliseconds)}}{\mathbf{TS} \text{ (in milliseconds)}}$$

### 3.2 Example:

This example will solve for the value **n**, with **n** = number of bytes which can Read “On-the-fly” at a given velocity. The BALOGH components being used are an OMX-931/8K byte TAG and ERC-85/QC Transceiver. We know that:

- V TAG** = 0.5m/s. = velocity at which a TAG passes through the Transmission zone of a Transceiver.  
**L Sr** = 0.06m = length of the Dynamic Transmission zone of an ERC-85/QC Transceiver.  
**TS** = 0.4ms \* **n** = OMX Read Transmission time in block mode. The variable is equal to the number of successive bytes between the start address and the end address.  
(10ms per byte + 50 ms for OMA TAG)  
(25ms + 5ms per byte for GIE TAG)  
(0.4ms per byte read and 0.6ms per byte written for OMX TAG)  
(70ms to read all 7 bytes for OF/OFR TAG)

The following equations determine the minimum acceptable length of time to Read or Write while “On-the-fly”:

$$\mathbf{Td} = \frac{\mathbf{L Sr} \quad 0.06\text{m}}{\mathbf{V TAG} \quad 0.5\text{m/s}} = 0.12\text{s}$$

$$\mathbf{Td} = 120\text{ms}$$

$$\mathbf{n} = \frac{\text{Number of bytes Transmitted:} \quad \mathbf{Td} \quad 120\text{ms}}{\mathbf{TS} \quad 0.4\text{ms/byte}} = 300 \text{ bytes}$$

$$\mathbf{n} = 300 \text{ bytes @ } \mathbf{Sr} \text{ (See TAG data sheet)}$$

### 3.3 Directional arrows

In order to ensure data exchange, the TAG and Transceiver should be correctly positioned according to the arrows indicating direction of travel. The arrows marked on each Transceiver and each TAG show:

- **The direction of travel.** Since they operate in pairs (one TAG opposite a Transceiver), it is important to check that the arrows on the TAG and Transceiver have the same orientation.
- **The center point of the Transmission zone.** Please refer to the appropriate data sheet for centering and mounting conditions.

Since inductive transmission is subject to certain physical laws, the following points should be carefully considered:

- Distance in metal free zones; see figs. 4.D, 4.E and 4.F
- Distance between two Transceivers; see fig. 4.M and table 4.2
- Distance between two TAGS; see fig. 4.C and table 4.3
- Coupling between Transceivers by interfering metallic antennas; see figs. 4.K, 4.L, and 4.M

## 4 Configuration recommendations:

### 4.1 Potential Transmission zones:

Potential Transmission zones are areas in which dialogue can take place with BALOGH TAGS (figs. 4.A and 4.B). BALOGH simplifies its RFID System by only using the Primary Transmission zone for data transmission. This zone represents the main arc in fig. 2.A. However, the other arcs that form potential Transmission zones are also present. Please read this chapter carefully and be sure to follow the recommendations for the minimum distances between two Transceivers or between two TAGS and one Transceiver.

**Figure 4.A Front View:**

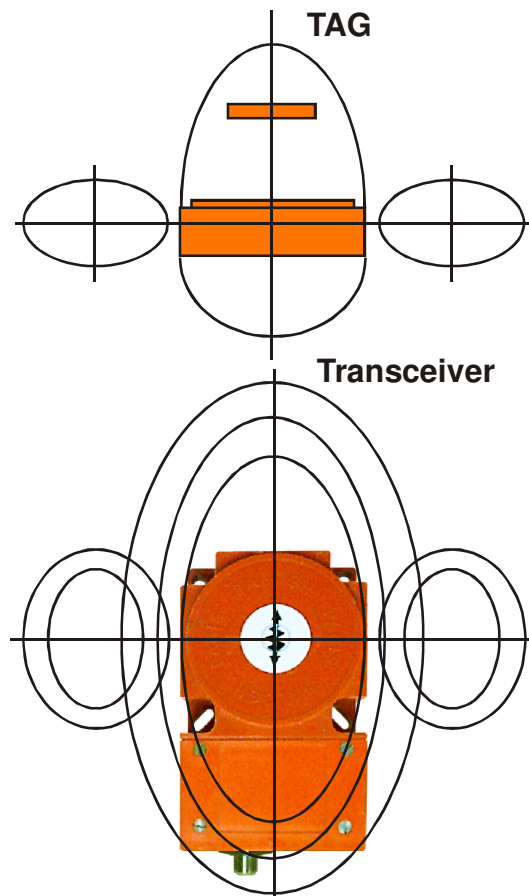

**Figure 4.B Top view:**

These concentric circles indicate the 3 dimensional field surrounding the TAG and Transceiver.

# Recommended Distance

## 4.2 Recommended distance between two Transceivers (Der):

To avoid interference between Transceivers, there must be a minimum space between them. The necessary distances are shown in the table below:

**TABLE 4.2:**

Distance between two Transceivers edge to edge (mm)	ERO-71/QC	ERO-85/QC	ERO-80/QC	ERA-18/QC	TLEB-891/PUR	TLE-18/B	ERC-85/QC	ERC-80/QC	ERA-80/QC
ERO-71/QC	250								
ERO-85/QC		1200							
ERO-80/QC			2000						
ERA-18/QC				80					
TLEB-891/PUR					200				
TLE-18/B						36			
ERC-85/QC							500		
ERC-80/QC								1450	
ERA-80/QC									400

\*For other combinations, please consult BALOGH.

## 4.3 Recommended distance between two TAGS (Det):

This safety feature (Det) prevents any Read or Write error caused by two TAGS entering the field of the same Transceiver (fig. 4.C).

**Figure 4.C Distance between two TAGS:**

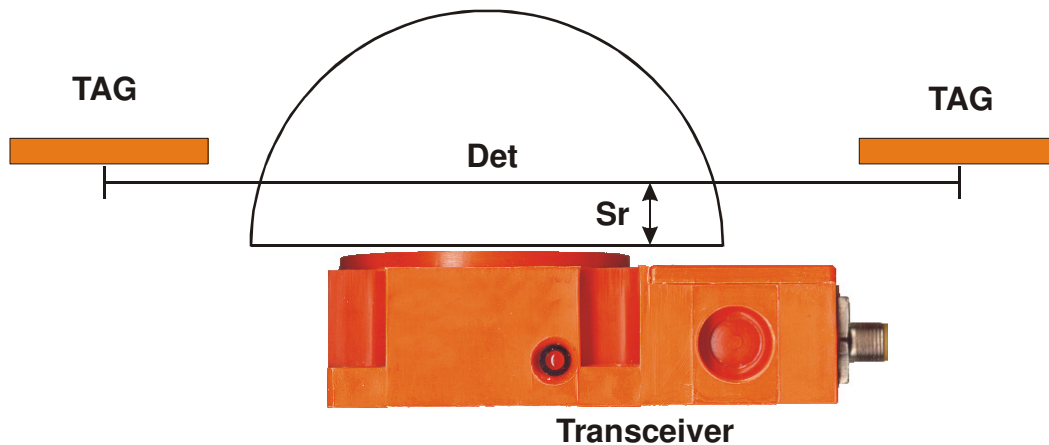

The values shown in the following table correspond to the maximum distance to be maintained between two TAGS of the same style relative to a Transceiver:

**Table 4.3:**

Distance between two TAGS (mm)	ERO-71/QC	ERO-85/QC	ERO-80/QC	TLEB-891/PUR	ERC-85/QC
OC-93		400	600		
OF-71	100	300	600	170	
OF-73	72	162		140	
OF-93	100	300	600	200	
OMA-181	75	240			
OMA-711	75	240		125	
OMA-731	72	162	172	100	
OMA-831	75	240	360		
OMA-851		330	540		
OMA-861		260			
OMA-931	75	240	360		
OMX-931/8K					200

Not all TAG and Transceiver combinations are shown. Consult product data sheet or contact BALOGH for more information.

#### 4.4 Transceiver mounting guidelines:

BALOGH Transceivers are designed to be operated in industrial environments on metal brackets. The metal bracket should be located on the back of the Transceiver, i.e. the side opposite the wiring chamber. All other metal surfaces surrounding the Transceiver should be no closer than the minimum distances specified in Table 4.4.

**Table 4.4:**

Dimensions (mm)	a	b
ERO-80/QC	100	50
ERO-85/QC	30	30
ERA-85/QC	20	20
ERO-71/QC	15	15
ERC-85/QC	30	30
TLEB-891/PUR	15	15

**Figure 4.D 80 Style Transceiver**

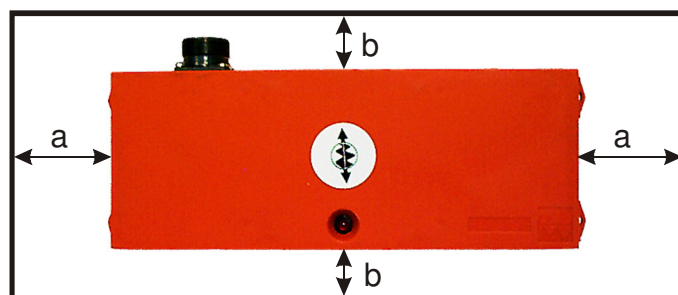

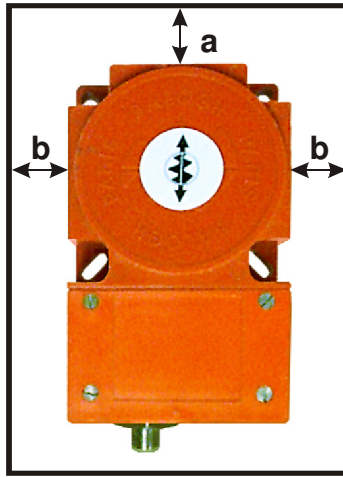

**Figure 4.E 85 Style Transceiver:**

- Not all Transceiver styles are shown. Consult BALOGH for more information.

**4.5 TAG mounting guidelines:**

BALOGH TAGS can be mounted in a recessed metal cavity if there is a space free of metal that corresponds to the values shown in the following table. The minimum metal-free clearance surrounding the TAG can be seen in figs. 4.G, 4.H, and 4.I:

**Table 4.5:**

Clearance (mm)	a	b
STYLE-85	30	30
STYLE-56	30	
STYLE-93	10	10
STYLE-71	10	10
STYLE-73	10	10

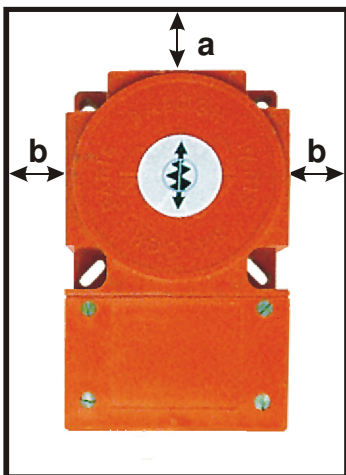

**Figure 4.G 85 Style TAG**

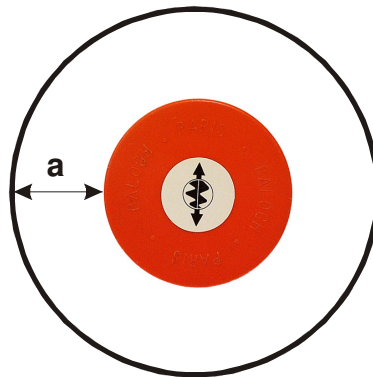

**Figure 4.H 56 Style TAG**

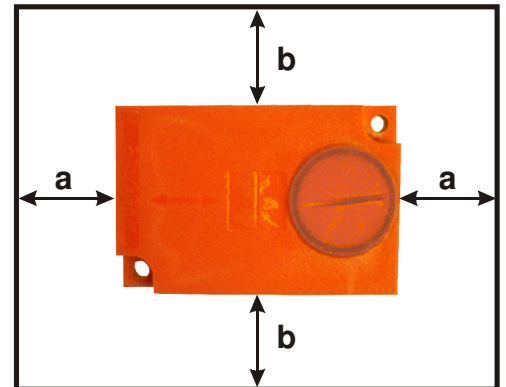

**Figure 4.I 93 Style TAG**

When mounting a TAG in a metallic environment, i.e. a metal bracket on a metal pallet, the values shown in the preceding table (4.5) must be maintained. These values represent the absolute minimum distances recommended for clearance between the TAG and the metal environment. Fig. 4.J shows an example using a 93 Style TAG in a metallic environment.

**Figure 4.J 93 Style TAG:**

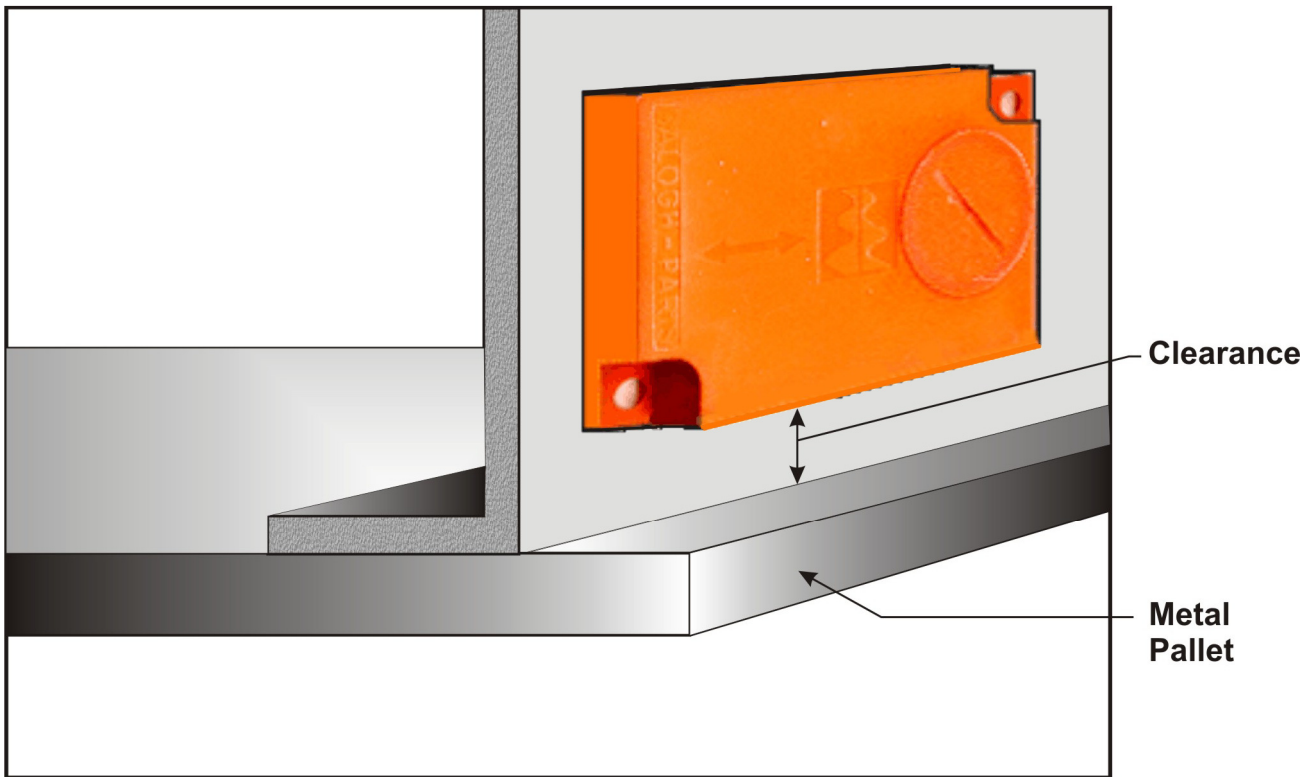

# Special Transceiver Configurations

**Figure 4.K:**

## 4.6 Special Transceiver configurations:

It is not recommended to mount 2 Transceivers in a conducting loop or within the vicinity of a conductor, which could form an electric loop. These configurations may form an antenna that would promote reciprocal interference to the Transceivers. Figs. 4.K and 4.L show examples of configurations that result in such influences.

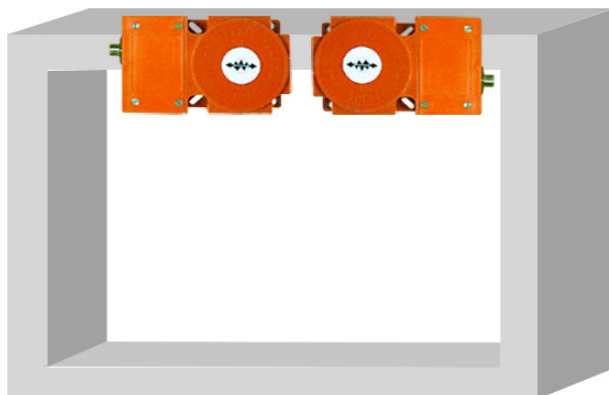

**Figure 4.L:**

Any position similar to figs. 4.K and 4.L may result in interference. Complying with the minimum distances and placing the Transceivers outside the loop will avoid problems of interference (fig. 4.M).



D = Minimum distance between 2 Transceivers.  
d = Distance between a Transceiver and a conductive loop.

**Figure 4.M:**

Minimum Distance (Meters)	D	d
ERO-71/QC	.25	.00
ERO-85/QC	1.2	.12
ERO-80/QC	2.0	0.2
ERA-80/QC	.40	.00

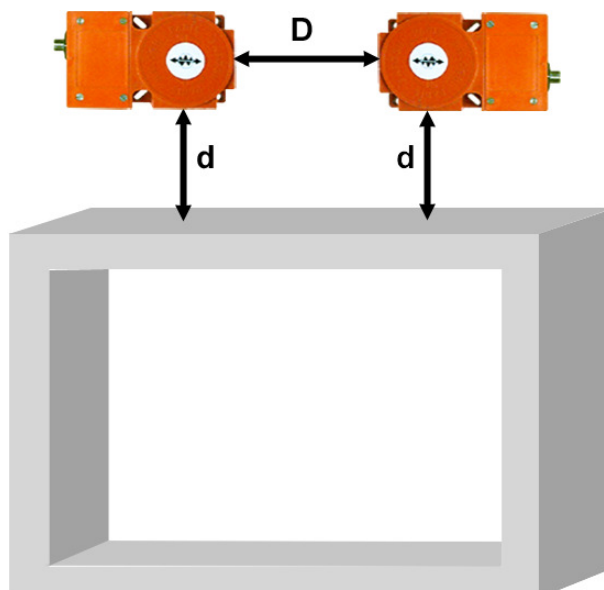

# 5 Electrical Connections

## 5.1 Power supply:

Supply voltage: 24V  
 Tolerance: - 20%; + 15%  
 Ripple ratio: 10%  
 Protection against: Polarity reversals  
 Max current input: 50 to 150mA

**Note:** The Control Board's power supply can be disrupted by rubbing contacts (distribution by rails). If lightning strikes, over-voltage could accidentally contact the network. It is recommended to distribute the power via a system for protecting and monitoring the voltage supplied.

## 5.2 Parallel connections:

### 5.2.1 Input characteristics:

Input impedance: 10 Kohms  
 Input level "0": 0 to + 10V  
 Input level "1": + 15V to + 24V  
 Protected against: Polarity reversals

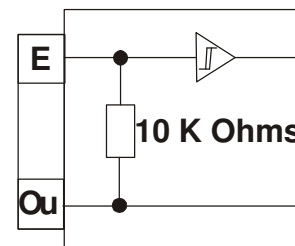
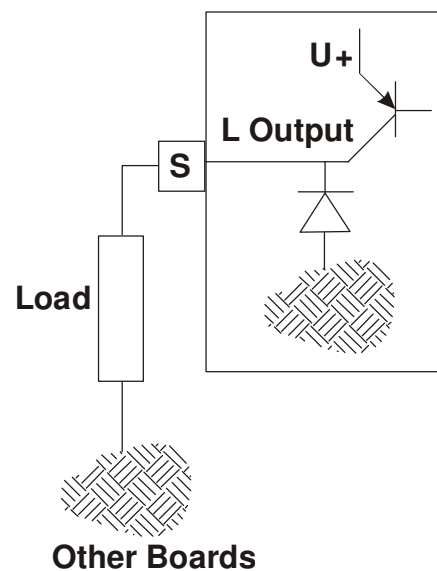
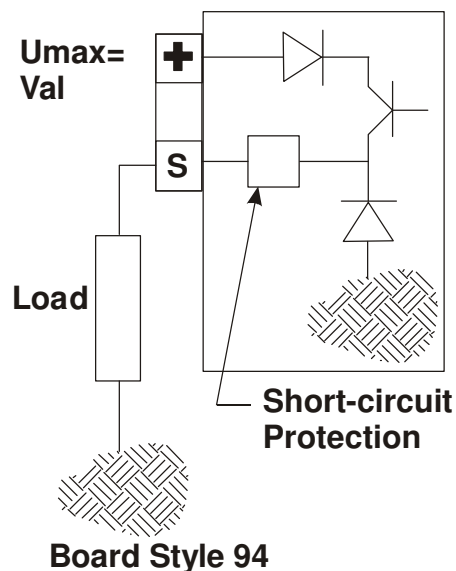

Fig. 5A Equivalent input diagram

### 5.2.2 Output characteristics:

Maximum continuous current supplied: 100mA to 250mA (depending on board style)  
 Logic 1: Supply Voltage-1.5V  
 Leakage current in logic 0: 0.5mA  
 Protected against load short circuits (94/95 series Control Boards)



# RS-232 Serial Connection

## 5.3.1 RS-232 Serial connection:

This type of connection is used for applications not requiring a long distance between the BALOGH Control Board and the user's system.

- Cable length: 15m
- Cable type: Shielded
- Conductor cross-section: 0.2 to 0.4mm<sup>2</sup>

### 5.3.1a Input characteristics:

- Input impedance: 3 Kohms
- Logic 0: +3V
- Logic 1: -3V

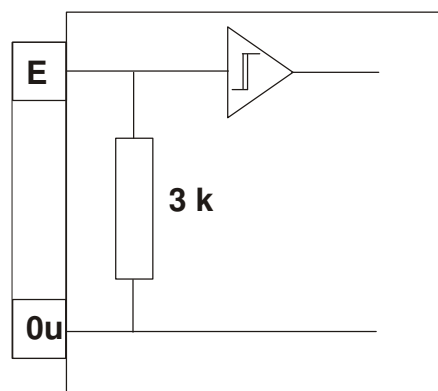

Equivalent diagram of 24V inputs

### 5.3.1b Output characteristics:

- Max. continuous current supply: 20mA
- Output logic 0 at 20mA: min +12V
- Output logic 1 at 20mA: min -12V
- Protected against: short-circuits

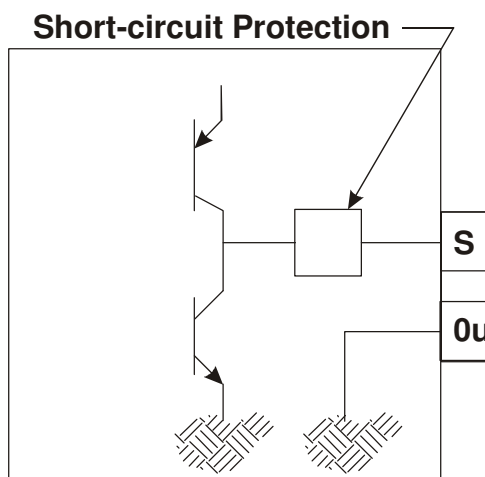

Equivalent diagram of 24V outputs

# Cable Transceiver Connections

## 5.4 Cable for Transceiver connection:

The following BALOGH Transceiver cable types should be used when wiring the BALOGH Transceivers and any BALOGH Control Board. The maximum recommended cable length will depend on the type of Transceiver used. Consult the Transceiver data sheet for specific length information.

SEF-ST or RA/\*, Single End Female-Straight Thru, or Right Angle/\* Length of cable

M-F/EXT/\*, Male-Female/Extension/\* Length of cable

BALOGH cables are polyurethane outer jacketed, twin pair, twin shielded cables. SEF cables have one female connector end and one pigtail end. M-F cables have connectors on both ends. Contact BALOGH for available lengths off the shelf and special order lengths.

### 5.4.1 Transceiver wiring:

BALOGH Transceiver cables should be used when making a connection between Control Boards and Transceivers.

- On the Transceiver side, the shielding is "open type" (not connected)
- On the board side, the shielding should be connected to the 0V on the board terminal block or "open type" (not connected)

The maximum cable length between a Transceiver and a board is 300m (1000 feet) for ERO series Transceivers. Consult the Transceiver data sheet for cable length. It is not advised to run the Transceiver control board cable in close proximity to conveying pulsating current.

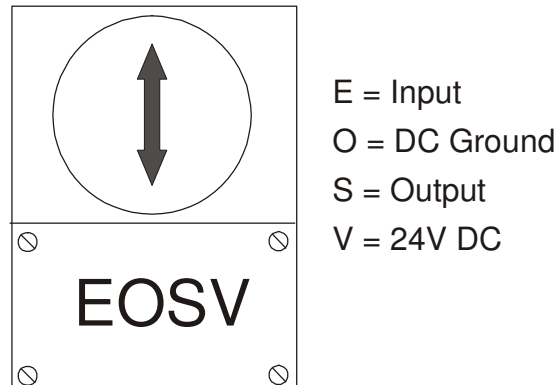

The Letters **E**, **O**, **S**, **V** appear either on the front of the Transceiver or inside the wiring chamber. When the keyed cap is removed from the Transceiver, four (4) saddle mount terminals will be shown. These correspond to the order of the letters on the cap. The 85 series Transceiver provides 3 port locations to install the Quick Connector (QC). Port #1 is the standard QC location. Port #2 and #3 are special order installations. When ordering an 85/QC Transceiver, a QC location sheet must accompany your order. If you need assistance in filling out this form or need one faxed to you, please contact BALOGH.

# Cable Applications

## 5.4.2 Cable applications:

### Overview:

Managing cable systems correctly can significantly reduce the risk of cable failure and reoccurring down time. Below is a list of common problems and simple solutions to these problems:

### Proper bend radius for Fixed and moving applications:

By providing a sufficient bend radius, you will greatly reduce the stress on the cable by distributing the stress over a greater length of the cable. This will provide a much longer cable life.

### Fixed applications:

Minimum bend radius 3 x cable diameter

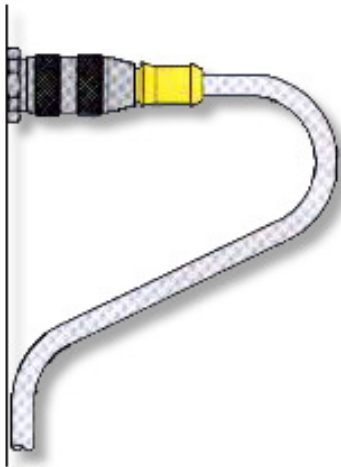

### Moving applications:

Minimum bend radius 10 x cable diameter

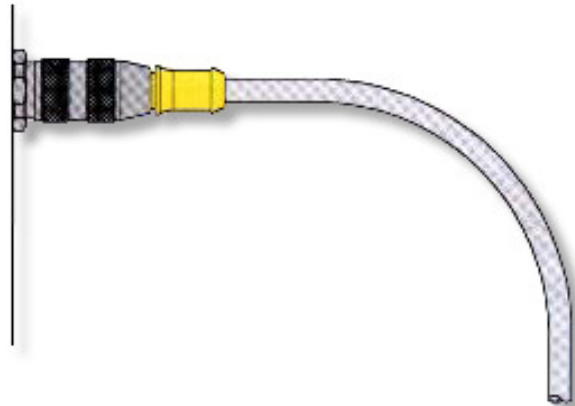

### Eliminating Stress Points in Cable Dress:

Installing cables to allow for adequate stress loops and freedom of motion increases the life of the cables.

### Strain Relief:

Correct



Incorrect

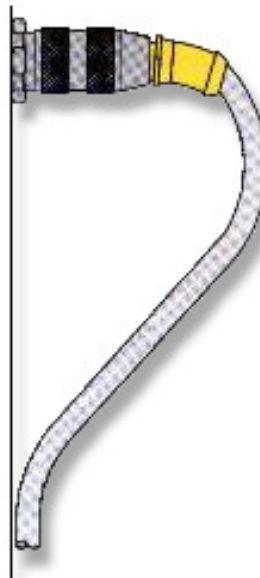

### Cable Bundling Techniques:

When you are bundling several cables together, be sure that they aren't tied too tightly together. Doing so will create stress and tension on the cables when the bundle is moved.

**Correct**

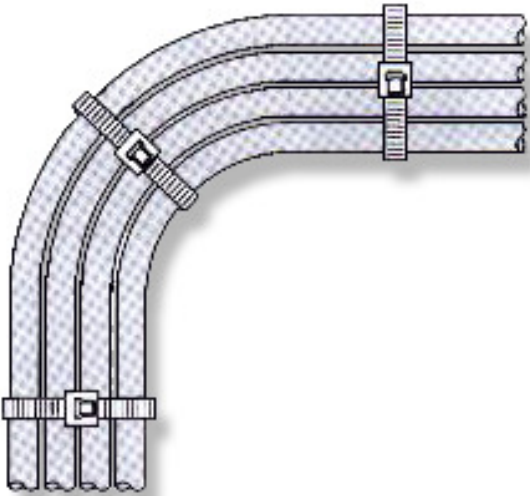

**Incorrect**

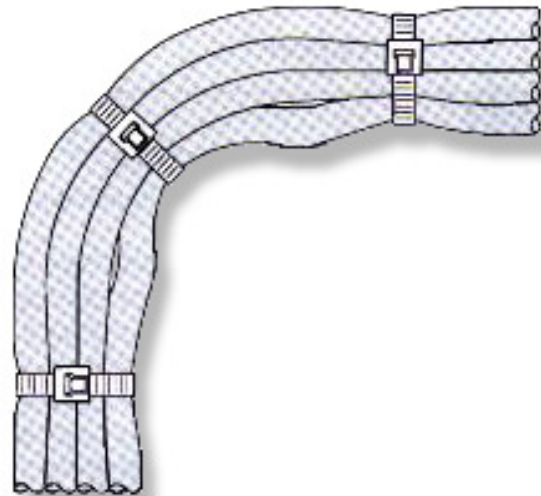

### Tying cables with cable ties:

When using self-locking style cable ties, be sure that they aren't tied too tightly. The ties should be loose enough so that the cable slides freely underneath it. Over-tightening the tie will cause the cable to fail prematurely. The cable jackets should never be deformed by the tie. If they are, the tie is too tight.

**Correct**

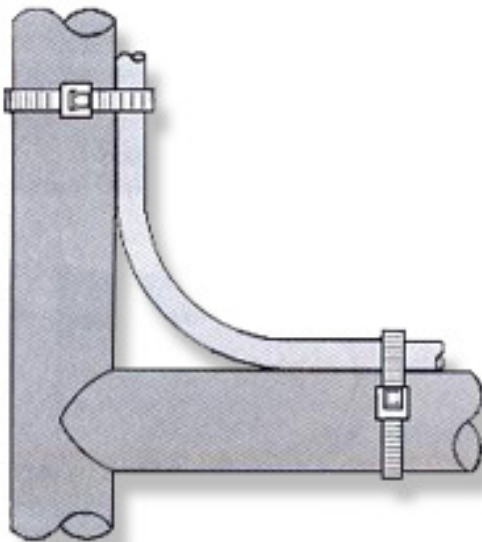

**Incorrect**

